



2506 South Elm Street
 Greenville, IL 62246
 www.enertechmfg.com
 info@enertechmfg.com

Installation, Operation & Maintenance: Multi-Positional Combination Units, GCT, HCT, & TCT Series

Rev.: 20 May 2011D

P/N:  23-23-0051-001

Table of Contents:

Section 1: Model Nomenclature
 Model Nomenclature2 - 4

Section 2: Introduction
 Introduction, Pre-Installation, Components5 - 6

Section 3: Installation Considerations
 Installation Considerations7

Section 4: Dimensional Data
 Unit Dimensional Data8

Section 5: Physical Data
 Unit Physical Data9

Section 6: Electrical Data
 Unit Electrical Data 10

Section 7: Installation
 Unit Placement 11
 Unit Conversion 12
 Ductwork Installation 13 - 15

Section 8: Unit Piping Installation
 Interior Piping, Water Quality 16 - 19

Section 9: Antifreeze
 Overview20
 Antifreeze Charging21 - 22

Section 10: Desuperheater Installation
 Installation23 - 25

Section 11: Controls
 Controls & Wiring Diagrams26 - 35

Section 12: Accessories
 Auxiliary Electric Heat36
 APSMA Pump Sharing Module36

Section 13: Troubleshooting
 Troubleshooting37 - 43

Section 14: Forms
 Troubleshooting, Unit Start-Up 45 & 47

Guide Revision Table:

Date	By	Page	Note
20 May 2010	DS	All	First published

Section 1a: GeoComfort® Series Model Nomenclature

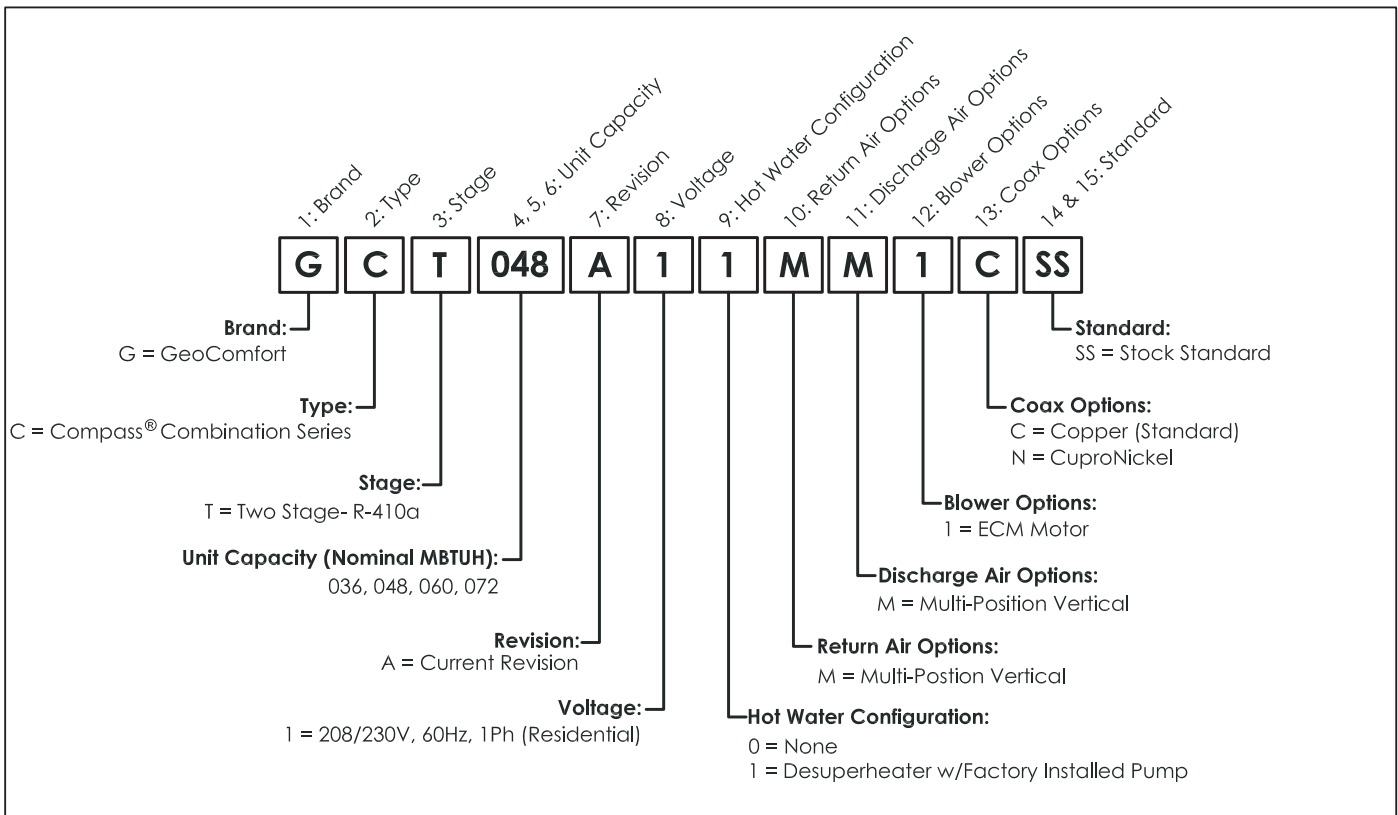

Rev.: 27 April 2011E

Section 1b: Hydron Module® Series Model Nomenclature

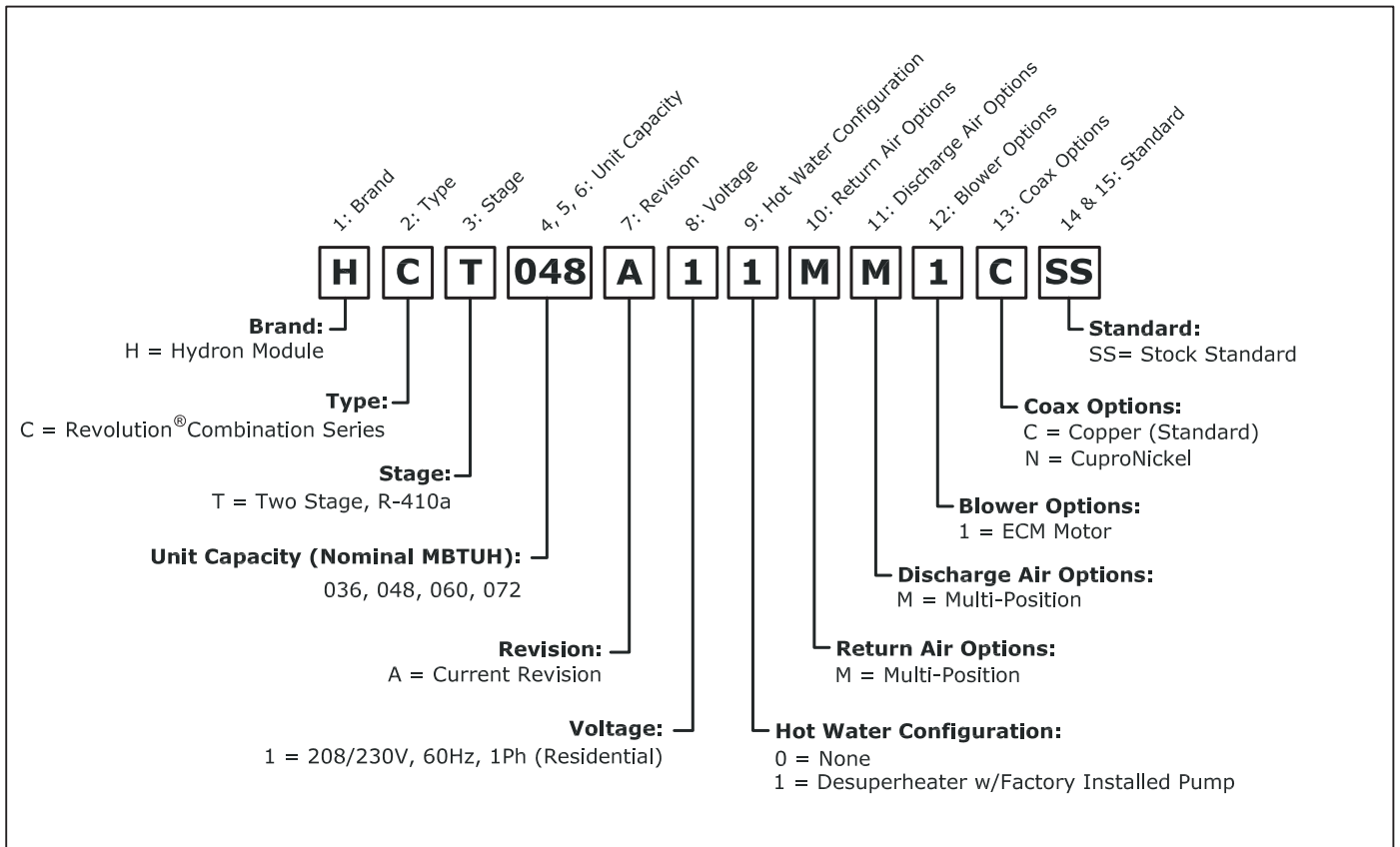

Rev.: 28 April 2011E

Section 1c: TETCO® Series Model Nomenclature

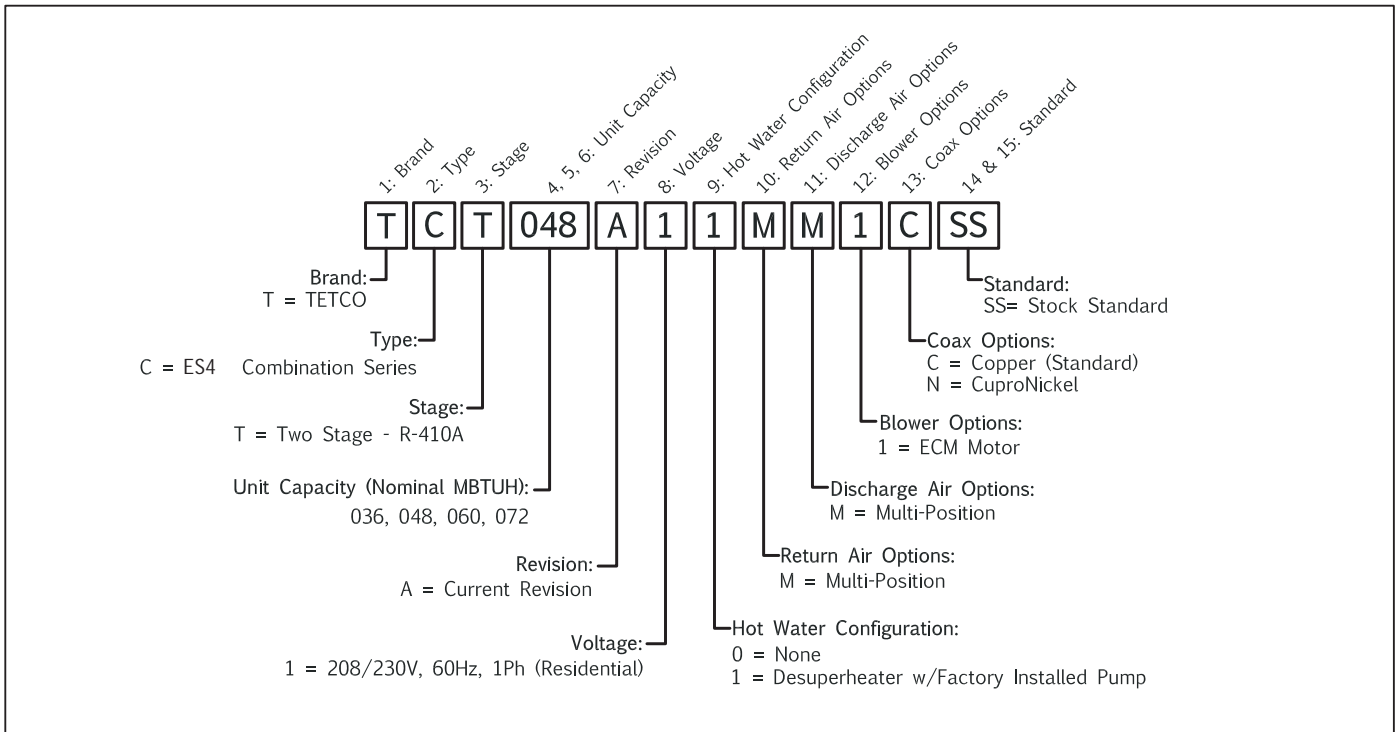

Rev.: 28 April 2011E

Section 2: Introduction

INTRODUCTION:

This geothermal heat pump provides heating and cooling as well as optional domestic water heating capability. Engineering and quality control is built into every geothermal unit. Good performance depends on proper application and correct installation.

Notices, Cautions, Warnings, & Dangers

“NOTICE” Notification of installation, operation or maintenance information which is important, but which is NOT hazard-related.

“CAUTION” Indicates a potentially hazardous situation or an unsafe practice which, if not avoided, COULD result in minor or moderate injury or product or property damage.

“WARNING” Indicates potentially hazardous situation which, if not avoided, COULD result in death or serious injury.

“DANGER” Indicates an immediate hazardous situation which, if not avoided, WILL result in death or serious injury.

Inspection:

Upon receipt of any geothermal equipment, carefully check the shipment against the packing slip and the freight company bill of lading. Verify that all units and packages have been received. Inspect the packaging of each package and each unit for damages. Insure that the carrier makes proper notation of all damages or shortage on all bill of lading papers. Concealed damage should be reported to the freight company within 15 days. If not filed within 15 days the freight company can deny all claims.

Note: Notify Enertech Manufacturing, LLC shipping department of all damages within 15 days. It is the responsibility of the purchaser to file all necessary claims with the freight company.

Unit Protection:

Protect units from damage and contamination due to plastering (spraying), painting and all other foreign materials that may be used at the job site. Keep all units covered on the job site with either the original packaging or

equivalent protective covering. Cap or recap unit connections and all piping until unit is installed. Precautions must be taken to avoid physical damage and contamination which may prevent proper start-up and may result in costly equipment repair.

⚠ CAUTION ⚠

DO NOT OPERATE THE GEOTHERMAL HEAT PUMP UNIT DURING BUILDING CONSTRUCTION PHASE.

Storage:

All geothermal units should be stored inside in the original packaging in a clean, dry location. Units should be stored in an upright position at all times. Units should not be stacked unless specially noted on the packaging.

Pre-Installation:

Special care should be taken in locating the geothermal unit. Installation location chosen should include adequate service clearance around the unit. All vertical units should be placed on a vibration-absorbing pad (air pad) slightly larger than the base of the unit. Flex connectors should also be installed in between the ductwork and the unit. All units should be located in an indoor area where the ambient temperature will remain above 55°F and should be located in a way that piping and ductwork or other permanently installed fixtures do not have to be removed for servicing and filter replacement.

Pre-Installation Steps:

1. Compare the electrical data on the unit nameplate with packing slip and ordering information to verify that the correct unit has been shipped.
2. Remove any packaging used to support or hold the blower during shipping.
3. Inspect all electrical connections and wires. Connections must be clean and tight at the terminals, and wires should not touch any sharp edges or copper pipe.

Section 2: Introduction

4. Verify that all refrigerant tubing is free of dents and kinks. Refrigerant tubing should not be touching other unit components.
5. Before unit start-up, read all manuals and become familiar with unit components and operation. Thoroughly check the unit before operating.

⚠ CAUTION ⚠

ALL GEOTHERMAL EQUIPMENT IS DESIGNED FOR INDOOR INSTALLATION ONLY. DO NOT INSTALL OR STORE UNIT IN A CORROSIVE ENVIRONMENT OR IN A LOCATION WHERE TEMPERATURE AND HUMIDITY ARE SUBJECT TO EXTREMES. EQUIPMENT IS NOT CERTIFIED FOR OUTDOOR APPLICATIONS. SUCH INSTALLATION WILL VOID ALL WARRANTIES.

⚠ WARNING ⚠

FAILURE TO FOLLOW THIS CAUTION MAY RESULT IN PERSONAL INJURY. USE CARE AND WEAR APPROPRIATE PROTECTIVE CLOTHING, SAFETY GLASSES AND PROTECTIVE GLOVES WHEN SERVICING UNIT AND HANDLING PARTS.

⚠ CAUTION ⚠

BEFORE DRILLING OR DRIVING ANY SCREWS INTO CABINET, CHECK TO BE SURE THE SCREW WILL NOT HIT ANY INTERNAL PARTS OR REFRIGERANT LINES.

Terminal Strip: Provides connection to the thermostat or other accessories to the low voltage circuit.

Transformer: Converts incoming (source) voltage to 24V AC.

Low Voltage Breaker: Attached directly to transformer, protects the transformer and low voltage circuit.

Blower Motor Relay: Energizes the blower motor (PSC motors only).

Reversing Valve: Controls the cycle of the refrigerant system (heating or cooling). Energized in cooling mode.

Three Way Valve: Is used with radiant water heating combination units. Energized in water heating mode.

High Pressure Switch: Protects the refrigerant system from high refrigerant pressure, by locking unit out if pressure exceeds setting.

Low Pressure Switch: Protects the refrigerant system from low suction pressure, if suction pressure falls below setting.

Flow Switch (Freeze Protection Device): Protects the water heat exchanger from freezing, by shutting down compressor if water flow decreases.

Electric Heater: Provides auxiliary heat during cold temperatures and provides electric backup if unit malfunctions.

Blower Motor (ECM): ECM (Electrically Communicated Motor) for variable fan speeds.

Compressor (Copeland Scroll): Pumps refrigerant through the heat exchangers and pressurizes the refrigerant, which increases the temperature of the refrigerant.

Components:

Master Contactor: Energizes Compressor and optional Hydronic Pump and/or Desuperheater package.

Logic Board: Logic Board operates the compressor and protects unit by locking out when safety switches are engaged. It also provides fault indicator(s).

Section 3: Installation Considerations

Consumer Instructions: Dealer should instruct the consumer in proper operation, maintenance, filter replacements, thermostat and indicator lights. Also provide the consumer with the manufacturer's Owner's Manual for the equipment being installed.

Enertech Manufacturing D-I-Y Policy: Enertech Manufacturing's geothermal heat pumps and system installations may include electrical, refrigerant and/or water connections. Federal, state and local codes and regulations apply to various aspects of the installation. Improperly installed equipment can lead to equipment failure and health/safety concerns. For these reasons, only qualified technicians should install a Enertech Manufacturing built geothermal system.

Because of the importance of proper installation, Enertech Manufacturing does not sell equipment direct to homeowners. Internet websites and HVAC outlets may allow for purchases directly by homeowners and do-it-yourselfers, but Enertech Manufacturing offers no warranty on equipment that is purchased via the internet or installed by persons without proper training.

Enertech Manufacturing has set forth this policy to ensure installations of Enertech Manufacturing geothermal systems are done safely and properly. The use of well-trained, qualified technicians helps ensure that your system provides many years of comfort and savings.

Equipment Installation: Special care should be taken in locating the unit. All vertical units should be placed on a vibration absorbing pad (air pad) slightly larger than the base of the unit. Downflow units should be placed on a non-combustible base. Flex connectors should also be installed in between the ductwork and the unit. All units should be located in an indoor area where the ambient temperature will remain above 55°F and should be located in a way that piping and ductwork or other permanently installed fixtures do not have to be removed for servicing and filter replacement.

Electrical: All wiring, line and low voltage, should comply with the manufacturer's recommendations, The National Electrical Code, and all local codes and ordinances.

Thermostat: Thermostats should be installed approximately 54 inches off the floor on an inside wall in the return air pattern and where they are not in direct sunlight at anytime.

Loop Pumping Modules: Must be wired to the heat pump's electric control box. A special entrance knockout is provided below the thermostat entrance knockout. A pump module connection block, connected to the master contactor, is provided to connect the Pump Module wiring.

Desuperheater Package: Water heating is standard on all residential units (units may be ordered without). It uses excess heat during both heating and cooling cycles, to provide hot water for domestic needs. A desuperheater exchanger (coil) located between the compressor and the reversing valve, extracts superheated vapor to heat domestic water; still satisfying its heating and cooling needs. The water circulation pump comes pre-mounted in all residential units, but must be electrically connected to the master contactor. Leaving it unconnected ensures that the pump is not run without a water supply. The Desuperheater package can make up to 60% (depending on heat pump usage) of most domestic water needs, but a water heater is still recommended.

Desuperheater Piping: All copper tubes & fittings should be 5/8" O.D (1/2" nom) minimum with a maximum of 50ft separation. Piping should be insulated with 3/8" wall closed cell insulation.

Note: Copper is the only approved material for desuperheater piping.

UV Light Usage: The use of a UV light in the unit return air plenum should be such that the light does not have a direct line of sight to the air coil of the unit. UV lights will cause the e-coat on the air coil to deteriorate. It would be better to place the UV light in the supply air plenum, or ductwork. This also helps keep the light cleaner. Additionally, if a humidifier is installed and in line of the sight of the UV light, consult the humidifier install manual for indication of whether the light will deteriorate any parts of the humidifier (like the pad).

Section 4: Equipment Dimensions

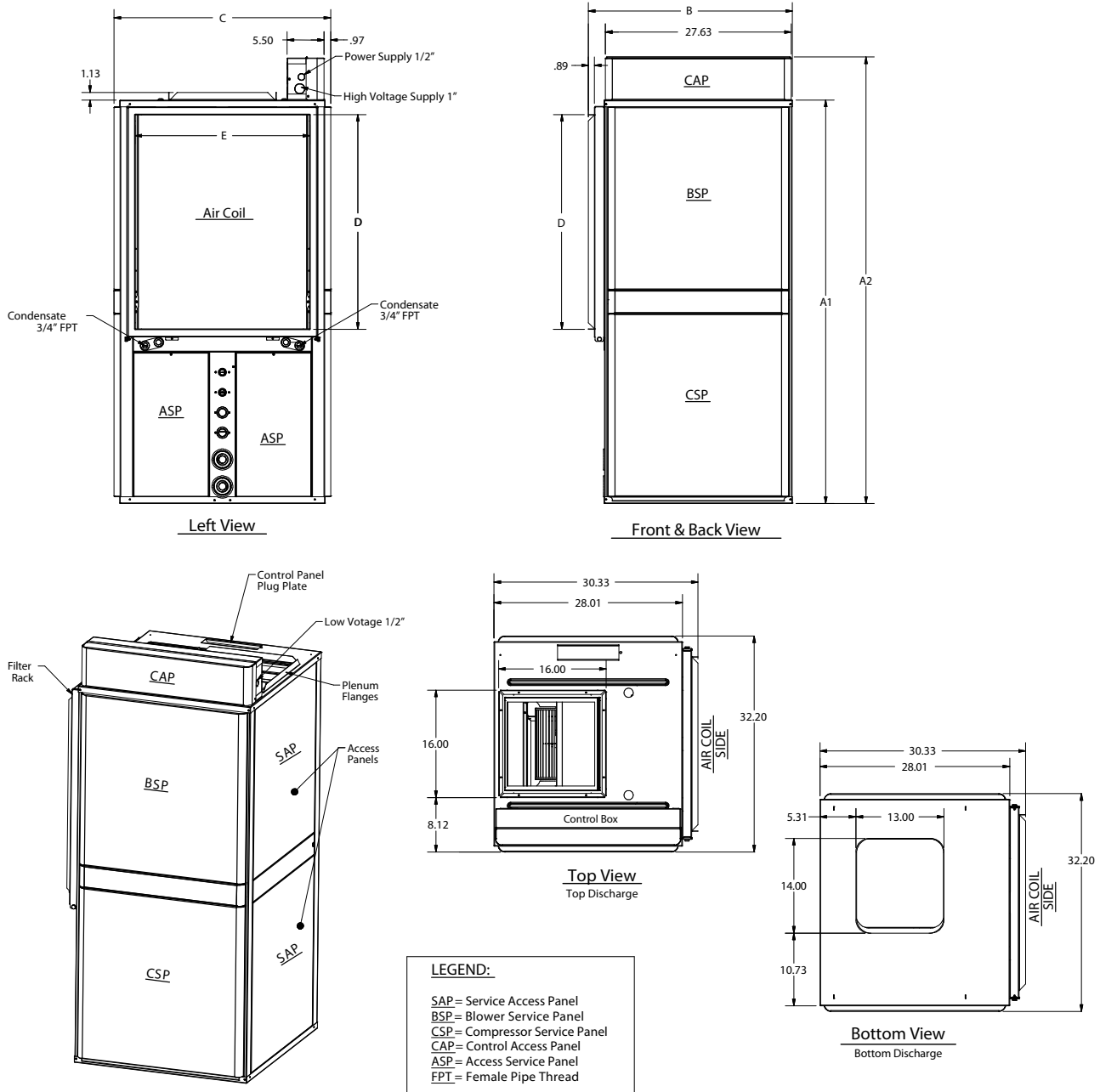

Model	Dimensional Data without Control Box			Dimensional Data with Control Box	Supply Air (Top Discharge)		Supply Air (Bottom Discharge)		Return Air	
	Height (A1)	Width (B)	Depth (C)	Height (A2)	Width	Depth	Width	Depth	Width (E)	Height (D)
024 - 036	56.1	30.3	32.2	62.5	16.0	16.0	13.0	14.0	26.0	28.0
048 - 072	60.1	30.3	32.2	66.5	16.0	16.0	16.0	16.0	26.0	32.0

Notes:

For the source water loop, GeoComfort models use 1" double o-ring fittings. Hydron Module & TETCO models use 1" FPT fittings. All models use 1" FPT fittings for load water loop connection. All Desuperheater connections are 3/4" FPT. All measurements are in inches.

Section 5: Unit Physical Data

Dual Capacity Vertical					
Model Number	024	036	048	060	072
Fan Wheel (in.)	Future Model	10 x 11	10 x 11	10 x 11	10 x 11
Fan Motor ECM (HP)		.5	1	1	1
Refrigerant Charge (oz.)		72	85	106	118
Air Coil					
Face Area (Sq.Ft.)		5.56	6.25	6.25	6.25
Dimensions (in.)		32 x 28.5 x 2.1	36 x 28.5 x 2.2	36 x 28.5 x 2.8	36 x 28.5 x 2.8
Number Of Rows		3	3	4	4
Filter 1" Thick		28 x 30 x 1	28 x 34 x 1		
Unit Weight (nominal) - lbs		450	490	535	550

Section 6: Unit Electrical Data

Two-Stage Packaged Units

Model	Voltage Code	60Hz Power		Compressor		ECM Fan Motor FLA	HWG Pump FLA	Ext Loop Pump FLA*	Total Unit FLA	Min Circuit AMPS	Max Fuse HACR	Min AWG	Max Ft
		Volts	Phase	LRA	RLA								
024	Future Model												
036	1	208/230	1	82.0	16.7	4.3	0.5	4.0	25.5	29.7	45	10	65
048	1	208/230	1	96.0	21.2	7.0	0.5	5.5	34.2	39.5	60	8	74
060	1	208/230	1	118.0	25.6	7.0	0.5	5.5	38.6	45.0	70	6	105
072	1	208/230	1	150.0	27.2	7.0	0.5	5.5	40.2	47.0	70	6	101

Notes:

1. All line and low voltage wiring must adhere to the National Electrical Code and local codes, whichever is the most stringent.
 2. Wire length based on a one way measurement with a 2% voltage drop.
 3. Wire size based on 60°C copper conductor and minimum circuit ampacity.
 3. All fuses class RK-5.
 4. Min/Max Voltage: 208/230/60/1 = 197/243.
- * The external loop pump FLA is based on a maximum of three UP26-116F-230V pumps (1/2hp) for 048 - 072 and two pumps for 024 - 036.

Section 7: Unit Placement

UNIT PLACEMENT:

When installing a geothermal heating and cooling unit, there are several items the installer should consider before placing the equipment.

1. **Service Access.** Is there enough space for service access? A general rule of thumb is at least 2 feet in the front and 2 feet on at least one side.
2. **Unit Air Pad.** All vertical geothermal heating and cooling equipment should be placed on either a formed plastic air pad, or a high density, closed cell polystyrene pad. Downflow units should be placed on a non-combustible base. This helps eliminate vibration noise that could be transmitted through the floor.
3. The installer has verified that all applicable wiring, ductwork, piping, and accessories are correct and on the job site.

PRE-INSTALLATION:

Before you fully install the geothermal equipment, it is recommended you go through this quick checklist before placing the equipment.

- Fully inspect the unit after unpacking.
- Open both the air handler section and compressor section and removed any packaging material or documentation included in the unit.
- Remove all packaging materials and ties from the rear of the blower.
- Locate the Unit Start-Up form from this manual and have it available as the unit installation proceeds.
- Clean the air coil with soap and water solution to remove any oil or dirt.

⚠ WARNING ⚠

DOWNFLOW UNITS REQUIRE THAT THE FLOOR OPENING (BETWEEN THE UNIT AND THE SUPPLY DUCT PLENUM) BE SLEEVED THROUGH THE FLOOR WITH METAL DUCT. THIS IS ESPECIALLY IMPORTANT IF THE UNIT IS SITTING ON AN AIR PAD.

⚠ NOTICE ⚠

THE BLOWER SUPPORT BRACKET, LOCATED ON THE BACK OF THE BLOWER FOR SHIPPING PURPOSES, MUST BE REMOVED BEFORE OPERATION. FAILURE TO REMOVE THE BRACKET COULD RESULT IN POTENTIALLY NOISY OPERATION AND EQUIPMENT DAMAGE.

⚠ NOTICE ⚠

THIS UNIT FEATURES A BRAZED-PLATE HEAT EXCHANGER FOR HYDRONIC HEATING. TO PREVENT POTENTIAL EQUIPMENT DAMAGE, A WATER STRAINER SHOULD BE INSTALLED IN THE WATER INLET CIRCUIT TO PROTECT THE HEAT EXCHANGER FROM PARTIAL OR COMPLETE BLOCKAGE WITH A 16-20 MESH MINIMUM, 20-40 MESH IS A BETTER CHOICE.

Section 7a: Unit Conversion

Figure 1: Unit Conversion

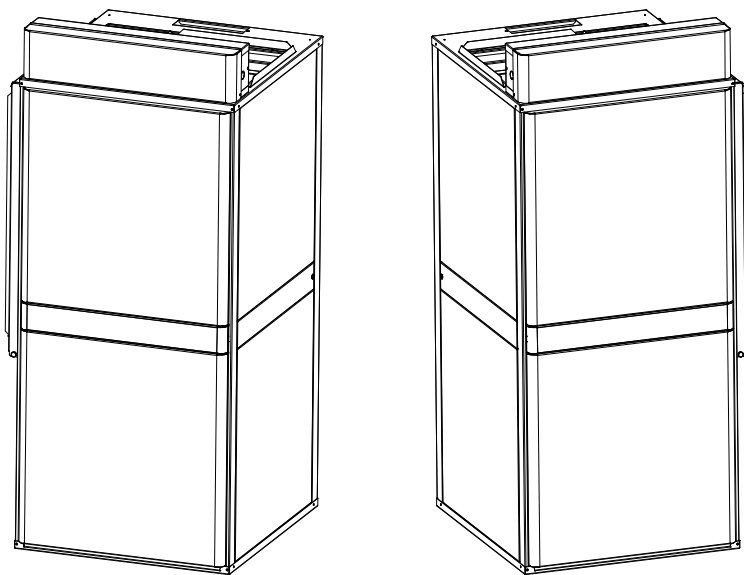

UNIT CONVERSION:

Units are shipped in the left hand return air, upflow configuration. The control box is shipped inside the unit. The control box plugs into the special mounting plate on the top of the unit.

To convert the unit to right hand return air:

1. Remove the front panels and rear panels. The panel screws are located under the band that runs across the middle of the unit. *(GeoComfort & Hydron Module units only)*
2. Rotate the unit to the correct position.
3. Move the unit controls connection plate from its current position (on the top of the unit) to the opposite side of the top of the unit. Use the block off plate from that side to cover the other side.
4. Mount the control box on what is now the top front of the unit. Plugs are available now to facilitate this.
5. Replace the front and rear panels onto the unit.

To convert the unit to downflow supply air:

1. Remove the screws holding the blower and heater housing and drop the assembly down.
2. Remove the block off plate from the area under the blower housing on the bottom blower area panel.
3. Place the block off plate over the opening where the blower housing was.
4. Install the downflow duct kit (instruction included with kit, ordered and shipped separately) in the compressor section of the unit.
5. Install the heater and blower housing assembly onto the downflow opening in the blower section securing it with the screws previously removed.

The source, hot water generator, and condensate fittings are on the air coil side of the unit, under the air coil itself. These connections are easier to facilitate if done prior to the fitting of the return air drop.

NOTE: Do not pry on the "belly band" that runs across the front of the unit to hide the access panel screws. Slight pressure on the rounded portion of the "belly band" will release the catch. *(GeoComfort & Hydron Module units only)*

Figure 2: Blower Housing Connections



Section 7b: Ductwork Installation

DUCT WORK:

All new ductwork shall be designed as outlined in Sheet Metal and Air Conditioning Contractors National Association (SMACNA) or Air Conditioning Contractors of America (ACCA) or American Society of Heating, Refrigerating and Air Conditioning Engineers (ASHRAE) handbooks.

All supply/return plenums should be isolated from the unit by a flexible connector (canvas) or equivalent to prevent transfer of vibration noise to the ductwork. The flex connector should be designed so as not to restrict airflow. Turning vanes should be used on any run over 500 CFM. If the unit is installed in a noninsulated space the metal ductwork should be insulated on the inside with fiberglass insulation or similar insulation to prevent heat loss/gain and to absorb air noise. If the unit is being installed with existing ductwork, the ductwork must be designed to handle the air volume required by the unit being installed. When running a cooling or heating load on a building, size ductwork accordingly to the building design load and heat pump CFM.

Industry Standard: When sizing ductwork use 400 CFM per Ton.

As a general rule, maximum recommended face velocity for a supply outlet used in a residential application is 800 FPM. Maximum recommended return grille velocity is 400 FPM. Systems with higher velocity, are likely to have noise problems.

In buildings where ceilings are 8 feet or more, at least 50 percent of the return air should be taken back to the heat pump from the ceiling or high sidewall location and not more than 50 percent from the floor or low sidewall location.

Table 1: Maximum Air Velocities

Location	Supply	Return
Main Ducts	900 FPM	600 FPM
Branch Ducts	700 FPM	600 FPM
Grills, Registers, Diffusers	750 FPM	600 FPM

Section 7b: Ductwork Installation

Figure 3: Standard Ductwork Connection Setup

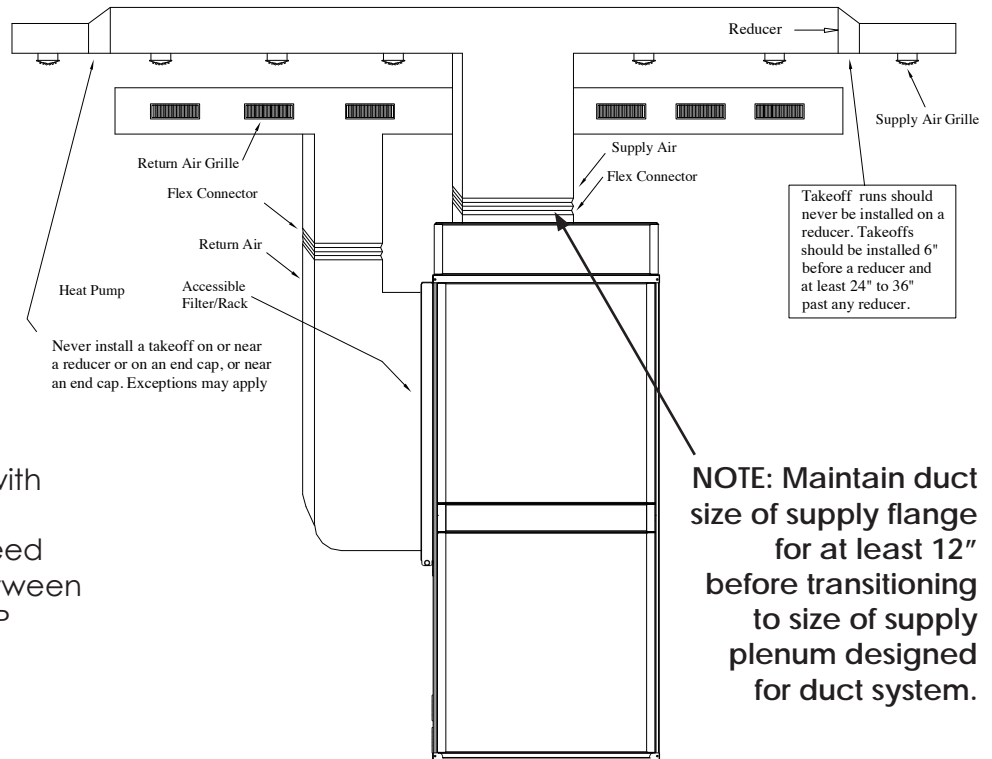

The geothermal unit comes with an ECM Motor. For maximum performance, the blower speed should be set to maintain between 350 and 450 CFM/ton. Use DIP switch for ECM motor.

Figure 4: Ductwork with Split Damper Connection Setup

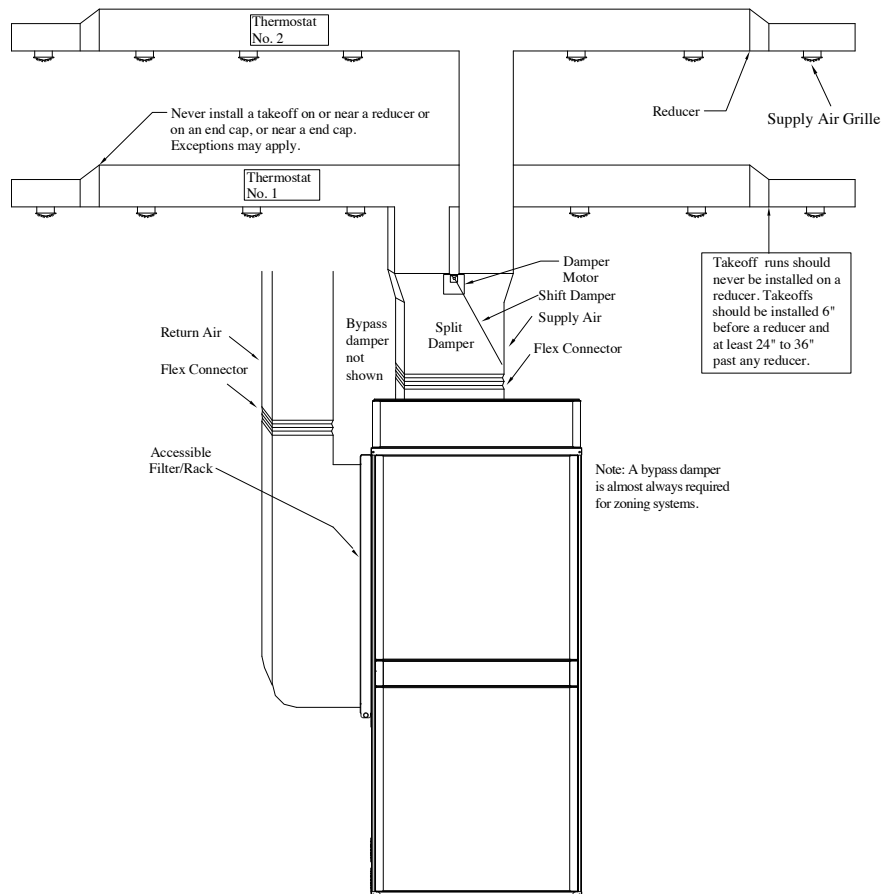

Section 8: Unit Piping Installation

Open Loop Piping

Placement of the components for an open loop system are important when considering water quality and long term maintenance. The water solenoid valve should always be placed on the outlet of the heat pump, which will keep the heat exchanger under pressure when the unit is not operating. If the heat exchanger is under pressure, minerals will stay in suspension. Water solenoid valves are also designed to close against the pressure, not with the pressure. Otherwise, they tend to be noisy when closing.

A flow regulator should be placed after the water solenoid valve. Always check the product specification catalog for proper flow rate. A calculation must be made to determine the flow rate, so that the leaving water temperature does not have the possibility of freezing.

Other necessary components include a strainer, boiler drains for heat exchanger flushing, P/T ports and ball valves. Ball valves allow the water to be shut off for service, and also help when velocity noise is noticeable through the flow regulator. Spreading some of the pressure drop across the ball valves will lessen the

velocity noise. Always double check flow rate at the P/T ports to make sure the ball valve adjustments have not lowered water flow too much, and essentially taken the flow regulator out of the equation. It's a good idea to remove the ball valve handles once the system is completed to avoid nuisance service calls.

Hose kits are optional, but make for an easier installation, since the P/T ports and connections are included. The hose also helps to isolate the heat pump from the piping system.

Two-stage units typically include two water solenoid valves, since the heat pump can operate at lower water flow on first stage, saving water. The flow regulators should be sized so that when one valve is open the unit operates at first stage flow rate, and when both valves are open, the unit operates at full load flow rate. For example, a 4 ton unit needs approximately 4 GPM on first stage, and approximately 7 GPM at full load. The flow regulator after the first valve should be 4 GPM, and the flow regulator after the second valve should be 3 GPM. When both valves are open, the unit will operate at 7 GPM.

Figure 5: Open Loop Piping Example

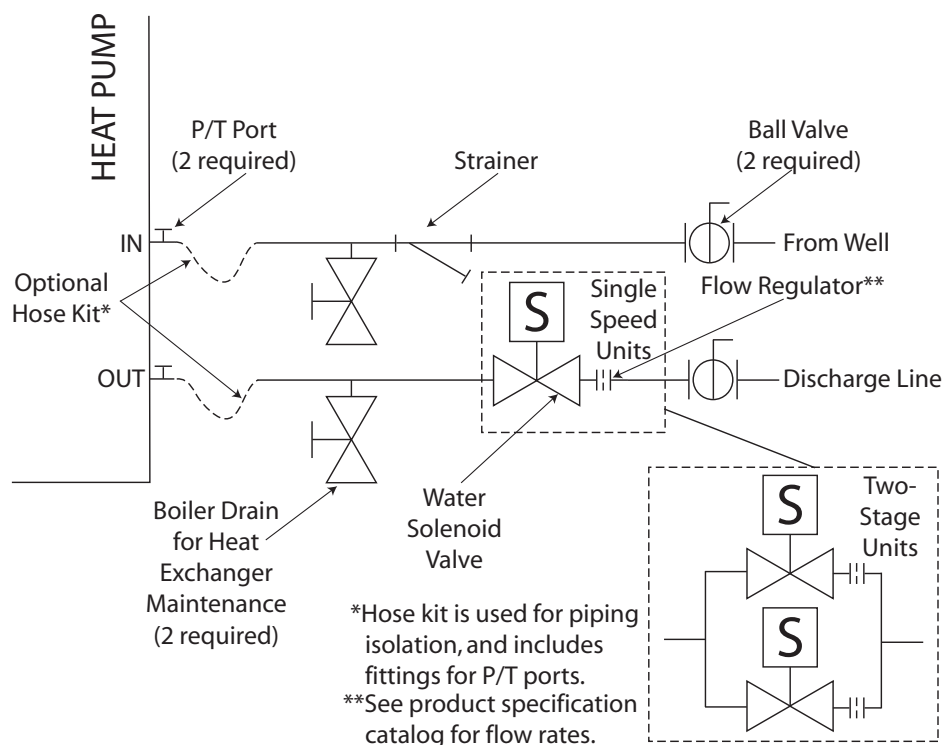

Note: All GCT/HCT/TCT units are two-stage units.

Section 8: Unit Piping Installation

Water Quality

The quality of the water used in geothermal systems is very important. In closed loop systems the dilution water (water mixed with antifreeze) must be of high quality to ensure adequate corrosion protection. Water of poor quality contains ions that make the fluid "hard" and corrosive. Calcium and magnesium hardness ions build up as scale on the walls of the system and reduce heat transfer. These ions may also react with the corrosion inhibitors in glycol based heat transfer fluids, causing them to precipitate out of solution and rendering the inhibitors ineffective in protecting against corrosion. In addition, high concentrations of corrosive ions, such as chloride and sulfate, will eat through any protective layer that the corrosion inhibitors form on the walls of the system.

Ideally, de-ionized water should be used for dilution with antifreeze solutions since de-

ionizing removes both corrosive and hardness ions. Distilled water and zeolite softened water are also acceptable. Softened water, although free of hardness ions, may actually have increased concentrations of corrosive ions and, therefore, its quality must be monitored. It is recommended that dilution water contain less than 100 PPM calcium carbonate or less than 25 PPM calcium plus magnesium ions; and less than 25 PPM chloride or sulfate ions.

In an open loop system the water quality is of no less importance. Due to the inherent variation of the supply water, it should be tested prior to making the decision to use an open loop system. Scaling of the heat exchanger and corrosion of the internal parts are two of the potential problems. The Department of Natural Resources or your local municipality can direct you to the proper testing agency. Please see Table 2 for guidelines.

Table 2: Water Quality

Potential Problem	Chemical(s) or Condition	Range for Copper Heat Exchangers	Range for Cupro-Nickel Heat Exchangers
Scaling	Calcium & Magnesium Carbonate	Less than 350 ppm	Less than 350 ppm
Corrosion	pH Range	7 - 9	5 - 9
	Total Dissolved Solids	Less than 1000 ppm	Less than 1500 ppm
	Ammonia, Ammonium Hydroxide	Less than 0.5 ppm	Less than 0.5 ppm
	Ammonium Chloride, Ammonium Nitrate	Less than 0.5 ppm	Less than 0.5 ppm
	Calcium Chloride / Sodium Chloride	Less than 125 ppm	Less than 125 ppm - Note 4
	Chlorine	Less than 0.5 ppm	Less than 0.5 ppm
	Hydrogen Sulfide	None Allowed	None Allowed
Biological Growth	Iron Bacteria	None Allowed	None Allowed
	Iron Oxide	Less than 1 ppm	Less than 1 ppm
Erosion	Suspended Solids	Less than 10 ppm	Less than 10 ppm
	Water Velocity	Less than 8 ft/s	Less than 12 ft/s

Notes:

1. Hardness in ppm is equivalent to hardness in mg/l.
2. Grains/gallon = ppm divided by 17.1.
3. Copper and cupro-nickel heat exchangers are not recommended for pool applications for water outside the range of the table. Secondary heat exchangers are required for applications not meeting the requirements shown above.
4. Saltwater applications (approx. 25,000 ppm) require secondary heat exchangers due to copper piping between the heat exchanger and the unit fittings.

Section 8: Unit Piping Installation

Interior Piping

All interior piping must be sized for proper flow rates and pressure loss. Insulation should be used on all inside piping when minimum loop temperatures are expected to be less than 50°F. Use the table below for insulation sizes with different pipe sizes. All pipe insulation should be a closed cell and have a minimum wall thickness of 3/8". All piping insulation should be glued and sealed to prevent condensation and dripping. Interior piping may consist of the following materials: HDPE, copper, brass, or rubber hose (hose kit only). **PVC is not allowed on pressurized systems.**

Typical Pressurized Flow Center Installation

The flow centers are insulated and contain all flushing and circulation connections for residential and light commercial earth loops that require a flow rate of no more than 20 gpm. 1-1/4" fusion x 1" double o-ring fittings (AGA6PES) are furnished with the double o-ring flow centers for HDPE loop constructions. Various fittings are available for the double o-ring flow centers for different connections. See table 1 for connection options. A typical installation will require the use of a hose kit. Matching hose kits come with double o-ring adapters to transition to 1" hose connection.

Table 3: Pipe Insulation

Piping Material	Insulation Description
1" IPS Hose	1-3/8" ID - 3/8" Wall
1" IPS PE	1-1/4" ID - 3/8" Wall
1-1/4" IPS PE	1-5/8" ID - 3/8" Wall
2" IPS PD	2-1/8" ID - 3/8" Wall

Note: Threaded flow centers all have 1" FPT connections. Matching hose kits come with the AGBA55 adapter needed to transition from 1" FPT to 1" hose.

Figure 6: Typical Single Unit Piping Connection (Pressurized Flow Center)

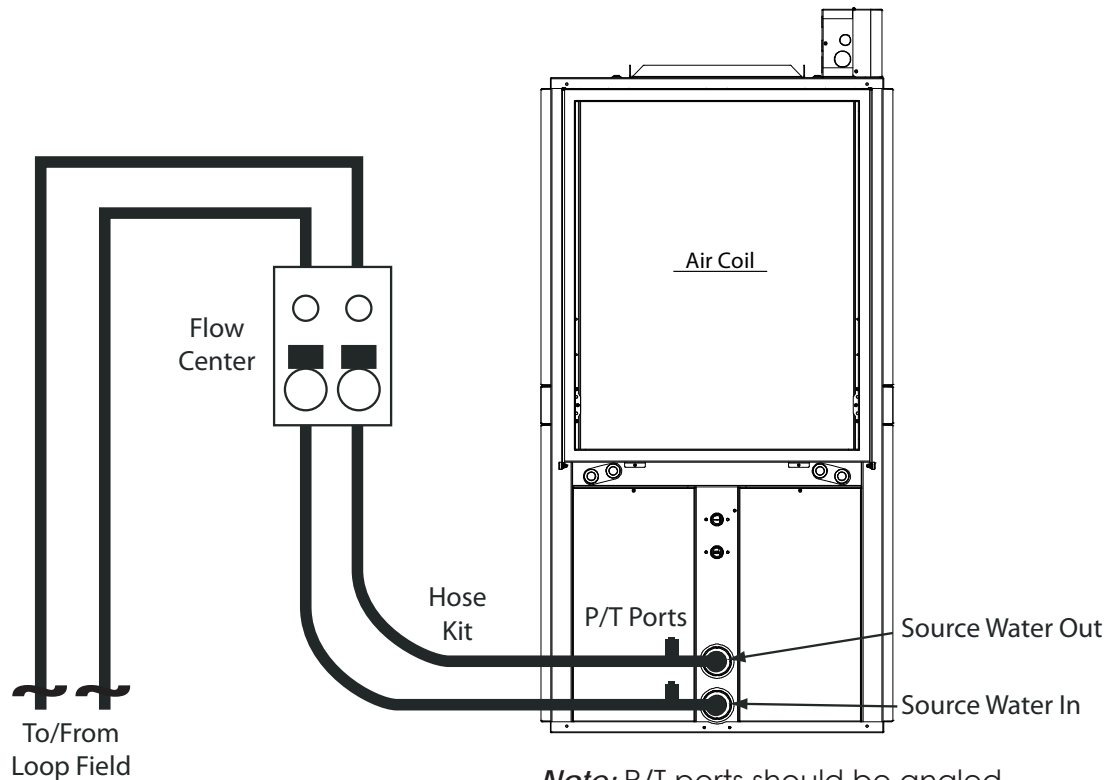

Note: P/T ports should be angled away from the unit for ease of gauge reading.

Section 8: Unit Piping Installation

Typical Non-Pressurized Flow Center Installation

Standing column flow centers are designed to operate with no static pressure on the earth loop. The design is such that the column of water in the flow center is enough pressure to prime the pumps for proper system operation and pump reliability. The flow center does have a cap/seal, so it is still a closed system, where the fluid will not evaporate. If the earth loop header is external, the loop system will still need to be

flushed with a purge cart. The non-pressurized flow center needs to be isolated from the flush cart during flushing because the flow center is not designed to handle pressure. Since this is a non-pressurized system, the interior piping can incorporate all the above-mentioned pipe material options (see interior piping), including PVC. The flow center can be mounted to the wall with the included bracket or mounted on the floor as long as it is properly supported.

Figure 7: Typical Single Unit Piping Connection (Non-Pressurized Flow Center)

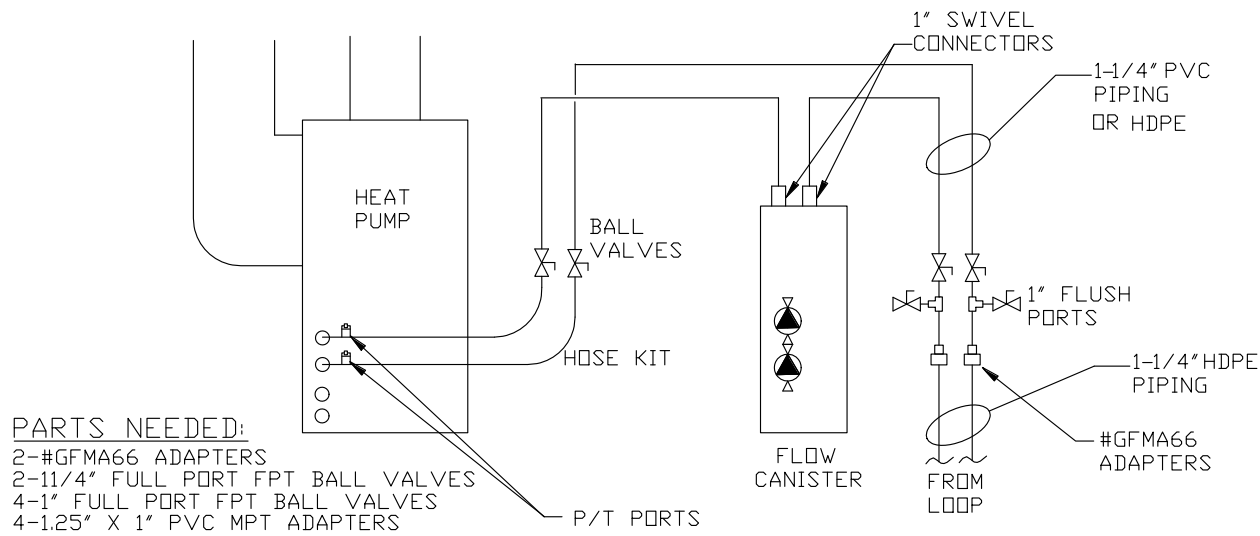
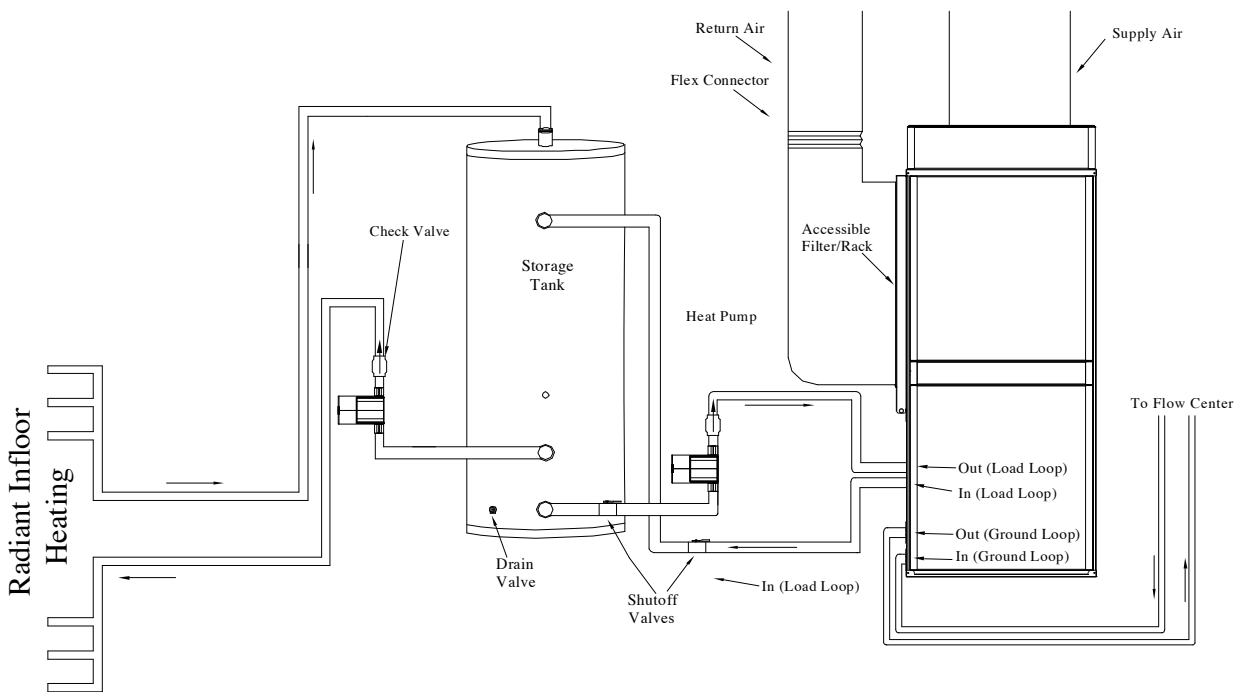

Figure 7: Typical Single Combination Unit Piping Connection



Section 8: Unit Piping Installation

⚠ NOTICE ⚠

THIS UNIT FEATURES A BRAZED-PLATE HEAT EXCHANGER FOR HYDRONIC HEATING. TO PREVENT POTENTIAL EQUIPMENT DAMAGE, A WATER STRAINER SHOULD BE INSTALLED IN THE WATER INLET CIRCUIT TO PROTECT THE HEAT EXCHANGER FROM PARTIAL OR COMPLETE BLOCKAGE WITH A 16-20 MESH MINIMUM, 20-40 MESH IS A BETTER CHOICE.

Condensation Drain Connection

Connect the EZ-Trap to the condensate drain on the equipment drain connection. The condensation line must be trapped a minimum of 1.0" as shown on diagram. The condensation line should be pitched away from the unit a minimum of 1/8" per foot. The top of trap must be below the drain connection. For more information on installing EZ-Trap, see installation sheet that comes with the EZ-Trap Kit.

Note: Connect the drain through the trap to the condensation drain system in conformance to local plumbing codes.

Part Number	Description
ACDT1A	EZ-Trap 3/4" Kit
ACDT2A	EZ-Trap 1" Kit

Figure 8: Condensation Drain Connection

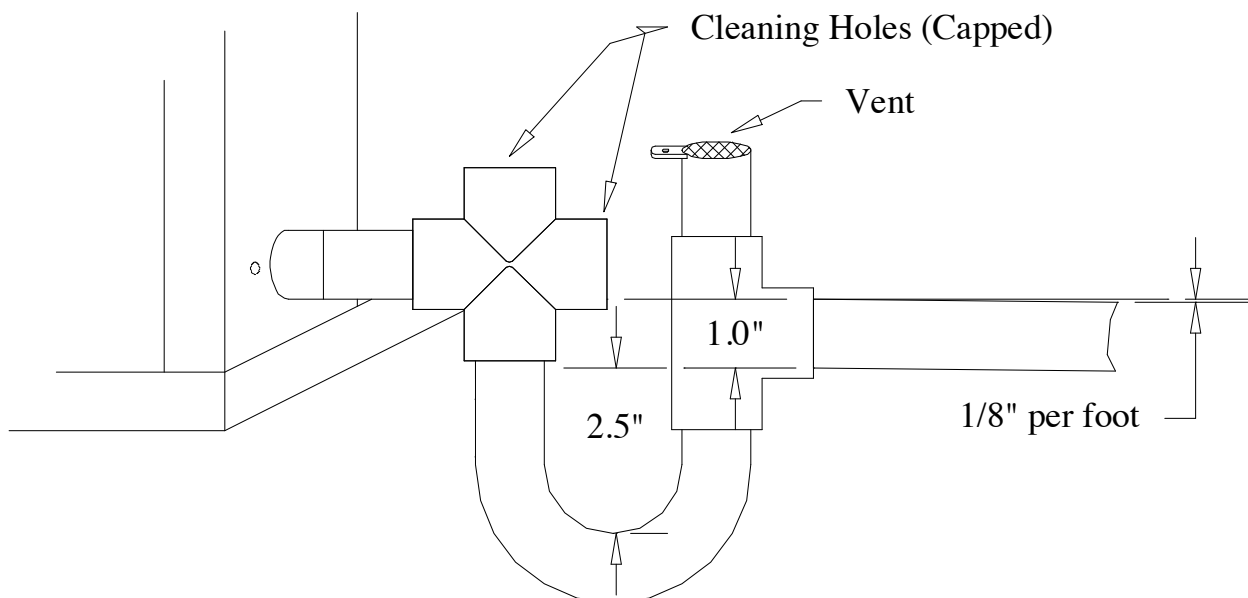

Section 9: Antifreeze

Antifreeze Overview

In areas where minimum entering loop temperatures drop below 40°F, or where piping will be routed through areas subject to freezing, antifreeze is required. Alcohols and glycols are commonly used as antifreeze. However, local and state/provincial codes supersede any instructions in this document. The system needs antifreeze to protect the coaxial heat exchanger from freezing and rupturing. Freeze protection should be maintained to 15°F below the lowest expected entering loop temperature. For example, if 30°F is the minimum expected entering loop temperature, the leaving loop temperature could be 22 to 25°F. Freeze protection should be set at 15°F (30-15 = 15°F). To determine antifreeze requirements, calculate how much volume the system holds. Then, calculate how much antifreeze will be needed by determining the percentage of antifreeze required for proper freeze protection. See Tables 3 and 4 for volumes and percentages. The freeze protection should be checked during installation using the proper hydrometer to measure the specific gravity and freeze protection level of the solution.

Antifreeze Characteristics

Selection of the antifreeze solution for closed loop systems require the consideration of many important factors, which have long-term implications on the performance and life of the equipment. Each area of concern leads to a different "best choice" of antifreeze. *There is no "perfect" antifreeze.* Some of the factors to consider are as follows (Brine = antifreeze solution including water):

Safety: The toxicity and flammability of the brine (especially in a pure form).

Cost: Prices vary widely.

Thermal Performance: The heat transfer and viscosity effect of the brine.

Corrosiveness: The brine must be compatible with the system materials.

Stability: Will the brine require periodic change out or maintenance?

Convenience: Is the antifreeze available and easy to transport and install?

Codes: Will the brine meet local and state/provincial codes?

The following are some general observations about the types of brines presently being used:

Methanol: Wood grain alcohol that is considered toxic in pure form. It has good heat transfer, low viscosity, is non-corrosive, and is mid to low price. The biggest down side is that it is flammable in concentrations greater than 25%.

Ethanol: Grain alcohol, which by the ATF (Alcohol, Tobacco, Firearms) department of the U.S. government, is required to be denatured and rendered unfit to drink. It has good heat transfer, mid to high price, is non-corrosive, non-toxic even in its pure form, and has medium viscosity. It also is flammable with concentrations greater than 25%. Note that the brand of ethanol is very important. Make sure it has been formulated for the geothermal industry. Some of the denaturants are not compatible with HDPE pipe (for example, solutions denatured with gasoline).

Propylene Glycol: Non-toxic, non-corrosive, mid to high price, poor heat transfer, high viscosity when cold, and can introduce micro air bubbles when adding to the system. It has also been known to form a "slime-type" coating inside the pipe. Food grade glycol is recommended because some of the other types have certain inhibitors that react poorly with geothermal systems. A 25% brine solution is a minimum required by glycol manufacturers, so that bacteria does not start to form.

Ethylene Glycol: Considered toxic and is not recommended for use in earth loop applications.

GS4 (POTASSIUM ACETATE): Considered highly corrosive (especially if air is present in the system) and has a very low surface tension, which causes leaks through most mechanical fittings. This brine is not recommended for use in earth loop applications.

Section 9: Antifreeze

Notes:

1. Consult with your representative or distributor if you have any questions regarding antifreeze selection or use.
2. All antifreeze suppliers and manufacturers recommend the use of either de-ionized or distilled water with their products.

Antifreeze Charging

Calculate the total amount of pipe in the system and use Table 3 to calculate the amount of volume for each specific section of the system. Add the entire volume together, and multiply that volume by the proper antifreeze percentage needed (Table 4) for the freeze protection required in your area. Then, double check calculations during installation with the proper hydrometer and specific gravity chart (Figure 9) to determine if the correct amount of antifreeze was added.

Table 4: Pipe Fluid Volume

Type	Size	Volume Per 100ft US Gallons
Copper	1" CTS	4.1
Copper	1.25" CTS	6.4
Copper	1.5" CTS	9.2
HDPE	.75 SDR11	3.0
HDPE	1" SDR11	4.7
HDPE	1.25" SDR11	7.5
HDPE	1.5: SDR11	9.8
HDPE	2" SDR11	15.4

Additional component volumes:

Unit coaxial heat exchanger = 1 Gallon

Flush Cart = 8-10 Gallons

10' of 1" Rubber Hose = 0.4 Gallons

⚠ CAUTION ⚠

USE EXTREME CARE WHEN OPENING, POURING, AND MIXING FLAMMABLE ANTIFREEZE SOLUTIONS. REMOTE FLAMES OR ELECTRICAL SPARKS CAN IGNITE UNDILUTED ANTIFREEZES AND VAPORS. USE ONLY IN A WELL VENTILATED AREA. DO NOT SMOKE WHEN HANDLING FLAMMABLE SOLUTIONS. FAILURE TO OBSERVE SAFETY PRECAUTIONS MAY RESULT IN FIRE, INJURY, OR DEATH. NEVER WORK WITH 100% ALCOHOL SOLUTIONS.

Section 9: Antifreeze

Table 5: Antifreeze Percentages by Volume

Type of Antifreeze	Minimum Temperature for Freeze Protection			
	10°F (-12.2°C)	15°F (-9.4°C)	20°F (-6.7°C)	25°F (-3.9°C)
ProCool (Ethanol)	25%	22%	17%	12%
Methanol	25%	21%	16%	10%
Propylene Glycol	38%	30%	22%	15%

All antifreeze solutions are shown in pure form - not premixed

NOTE: Most manufacturers of antifreeze solutions recommend the use of de-ionized water. Tap water may include chemicals that could react with the antifreeze solution.

Figure 9: Antifreeze Specific Gravity

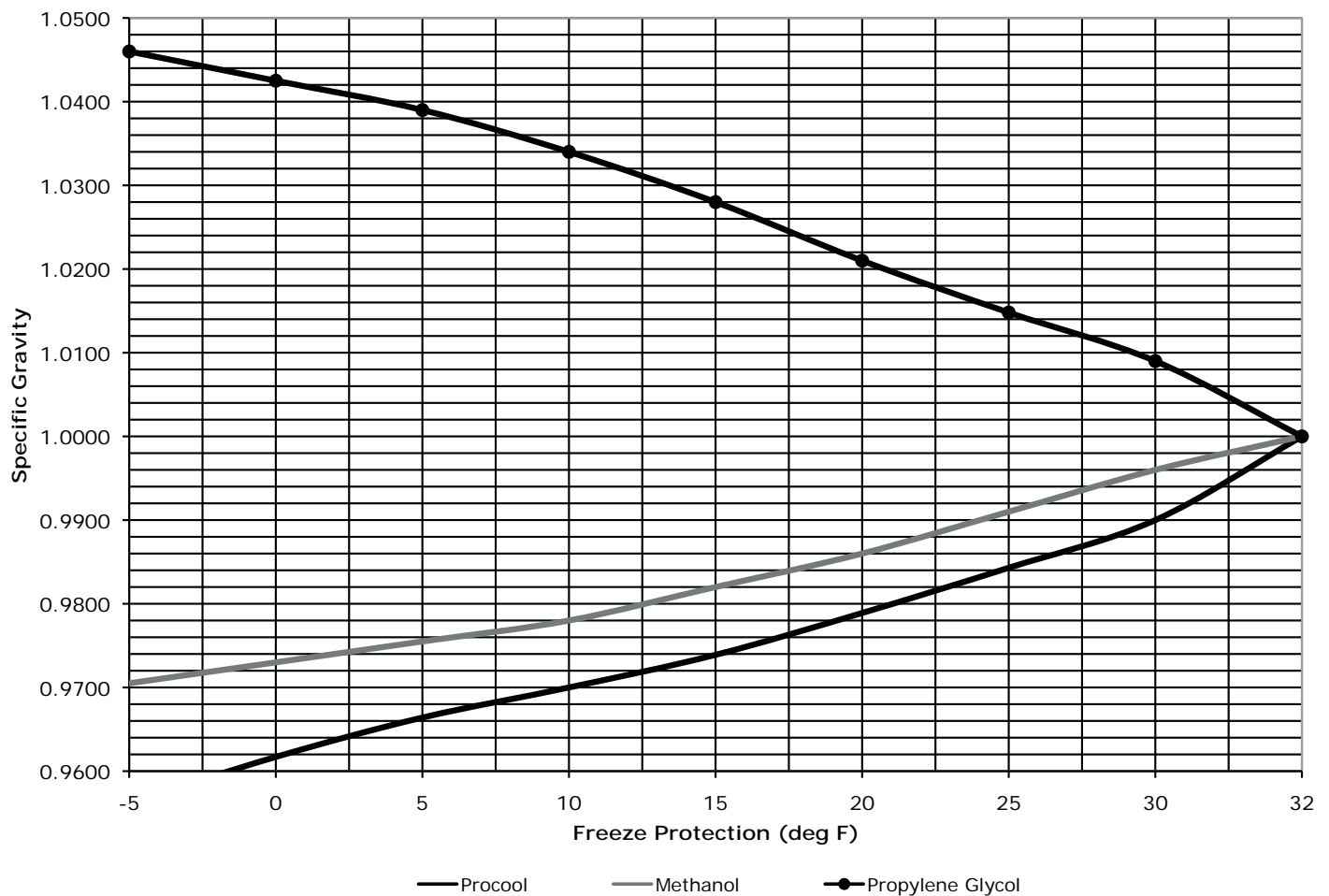

Section 10: Desuperheater Installation

Desuperheater Installation

Units that ship with the desuperheater function also ship with a connection kit.

Note: Desuperheater capacity is based on 0.4 GPM Flow per nominal ton at 90°F entering hot water temperature.

Note: Units that are shipped with a desuperheater do not have the desuperheater pump wires connected to the electrical circuit, to preclude accidentally running the pump while dry. Pump has to be connected to the electric circuit (master contactor) when the lines from the water heater are installed & air is removed.

CONTENTS OF THE DESUPERHEATER FITTING KIT:

- (1) p/n 23-23-0024-001, Installation Instructions
- (1) p/n 11-08-0004-001, 3/4"x 3/4"x 3/4" FPT Brass Tee
- (1) p/n 11-08-0003-001, 3/4" Boiler Drain Valve
- (1) p/n 11-08-0005-001, 3/4" MPT x 3-1/2" Brass Nipple
- (3) p/n 11-08-0006-001, 1/2" SWT x 3/4" MPT Copper Adaptor
- (1) p/n 11-08-0007-001, 3/4" x 3/4" x 1/2" SWT Copper Tee

Plumbing Installation

NOTE: All plumbing and piping connections must comply with local plumbing codes.

TIP: Measure the distance above the floor or shelf that the water heater is setting on, to where the drain valve is located. This distance must be greater than one-half the width of the tee you're about to install, or you won't be able to thread the tee on to the water heater.

1. Disconnect electricity to water heater.
2. Turn off water supply to water heater.
3. Drain water heater. Open pressure relief valve.
4. Remove drain valve and fitting from water heater.
5. Thread the 3/4" MPT x 3-1/2" nipple into the water heater drain port. Use Teflon tape, or pipe dope on threads.
6. Thread the center port of the 3/4" brass tee to the other end of the nipple.
7. Thread one of the copper adaptors into the end of the tee closest to the heat pump.
8. Thread the drain valve into the other end of the nipple. See Figure 10.
9. Above the water heater, cut the incoming cold water line. Remove a section of that line to enable the placement of the copper tee.
10. Insert the copper tee in the cold water line. See Figure 11.
11. Thread the remaining two 1/2" SWT x 3/4" MPT copper adaptors into the 3/4" FPT fittings on the heat pump, marked HOT WATER IN and HOT WATER OUT.
12. Run interconnecting 1/2" copper pipe from the HOT WATER OUT on the heat pump, to the copper adaptor located on the tee at the bottom of the water heater (Step 7).
13. Run interconnecting 1/2" copper pipe from the HOT WATER IN on the heat pump, to the copper tee in the cold water line (Step 10).
14. Install an air vent fitting at the highest point of the line from step 13 (assuming it's the higher of the two lines from the heat pump to the water heater). See Figure 11.
15. Turn the water supply to the water heater on. Fill water heater.

Section 10: Desuperheater Installation

16. Flush the interconnecting lines, and check for leaks.
17. Install 3/8" closed cell insulation on the lines connecting the heat pump to the water heater.
18. Reconnect electricity to water heater.

Figure 10: Water Heater Connection Kit Assembly for Bottom of Water Heater

NOTE: Drawing shown vertically for detail. Fitting installs horizontally into hot water tank.

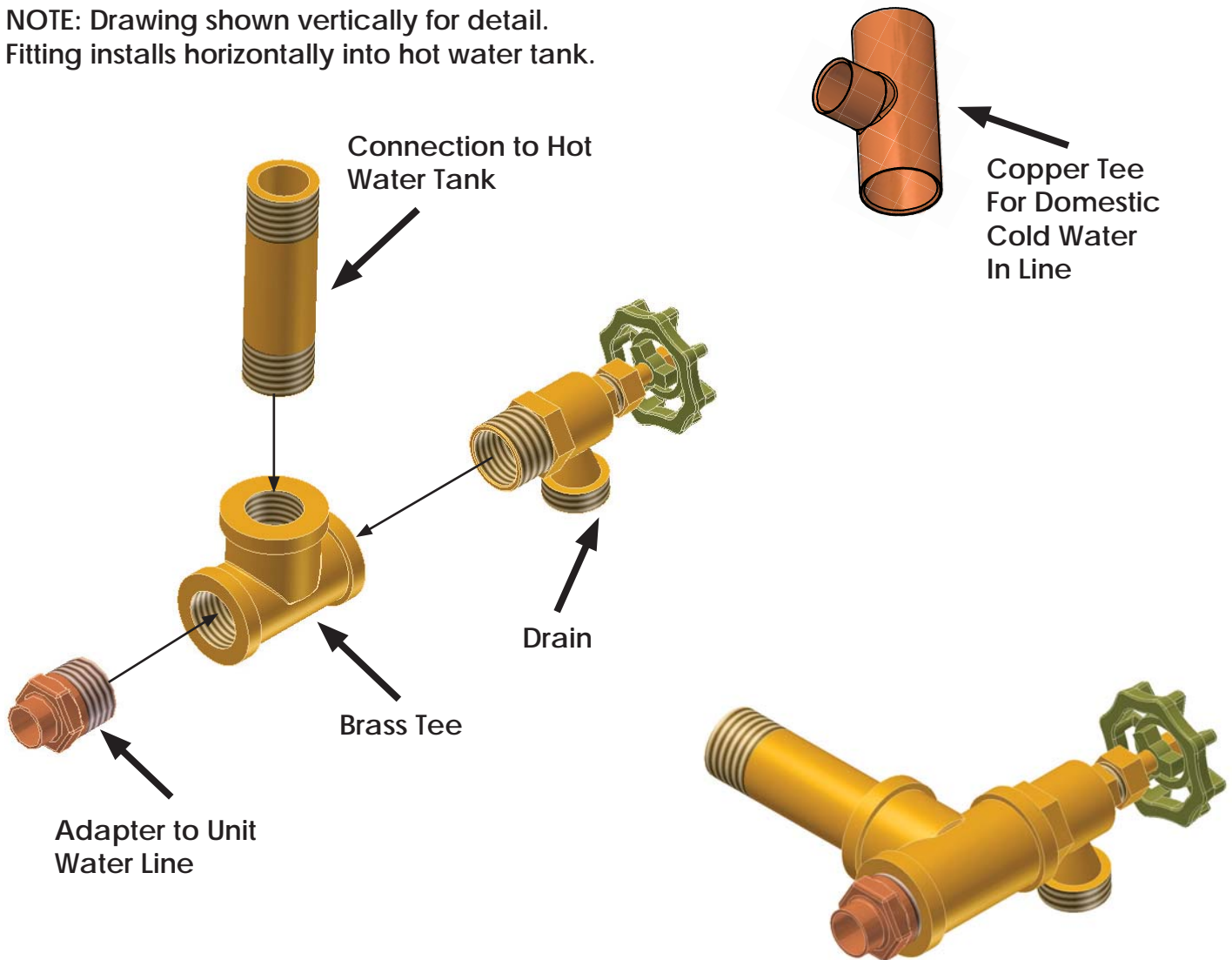

Section 10: Desuperheater Installation

Figure 11: Typical Desuperheater Installation

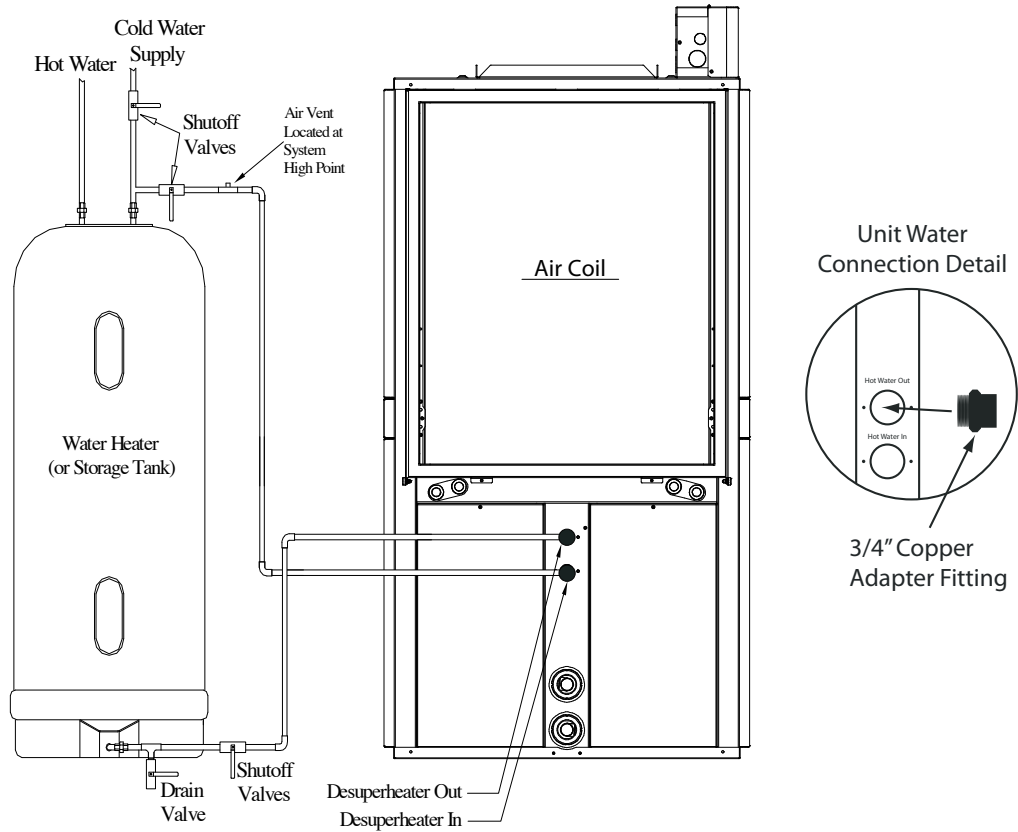
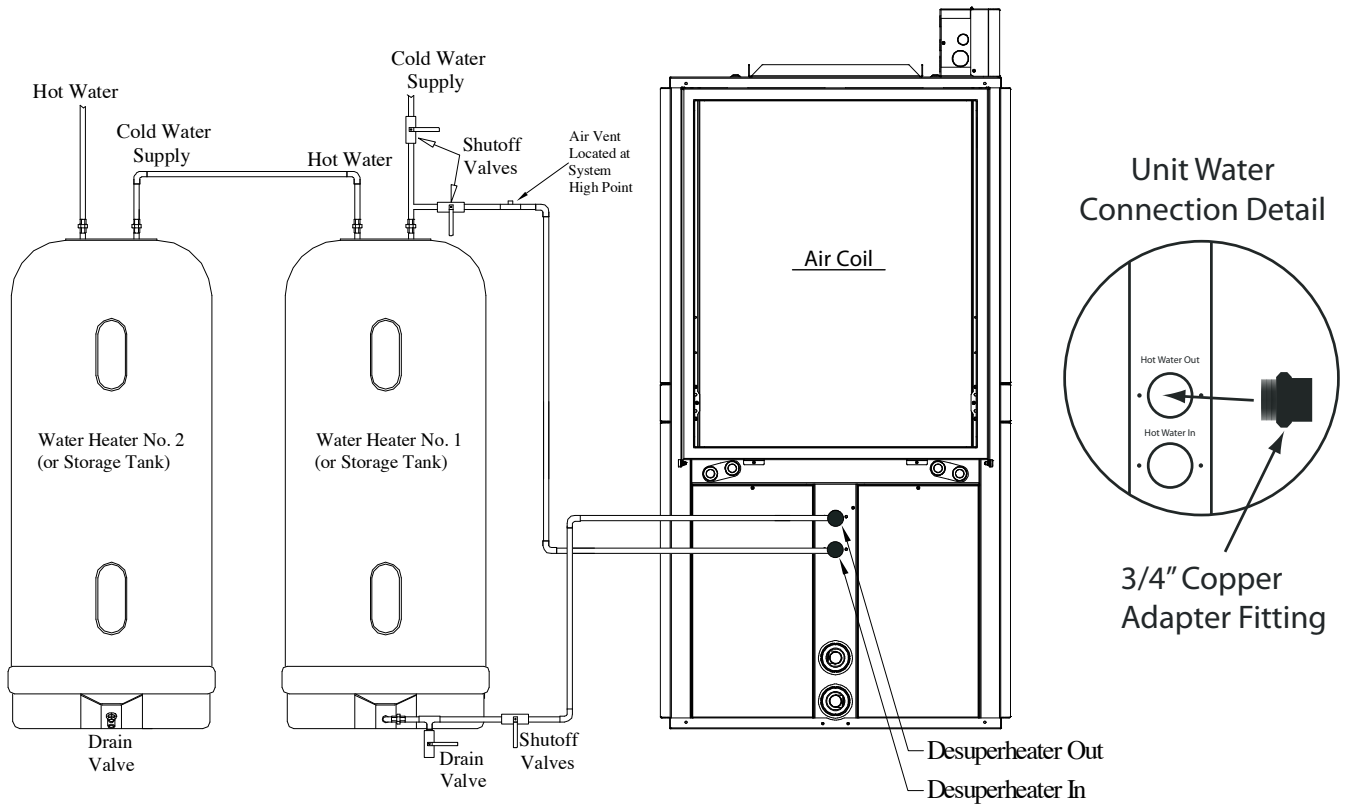

Figure 12: Desuperheater Installation with Preheat Tank



Section 11a: Controls

MICROPROCESSOR FEATURES AND OPERATION

Enertech Manufacturing geothermal heat pump controls provide a unique modular approach for controlling heat pump operation. The control system uses one, two, or three printed circuit boards, depending upon the features of a particular unit. This approach simplifies installation and troubleshooting, and also eliminates features that are not applicable for some units.

A microprocessor-based printed circuit board controls the inputs to the unit as well as outputs for status mode, faults, and diagnostics. A status LED and an LED for each fault is provided for diagnostics. An ECM control module provides field selectable options for airflow and dehumidification mode, plus an LED to indicate CFM (100 CFM per flash). If the combination unit is desired (combination water-to-air and water-to-water heat pump), a third board controls the hydronic portion of the unit, allowing field selectable hot water/forced air priority and other options.

Removable low voltage terminal strips provide all necessary terminals for field connections. Not only are the thermostat inputs included, but there are also two additional removable terminal strips for all of the accessory and electric heat wiring for ease of installation and troubleshooting.

Startup/Random Start

The unit will not operate until all the inputs and safety controls are checked for normal conditions. At first power-up, the compressor is energized after a five minute delay. In addition, a zero to sixty second random start delay is added at first power-up to avoid multiple units from being energized at the same time.

Short Cycle Protection

A built-in five minute anti-short cycle timer provides short cycle protection of the compressor.

Component Sequencing Delays

Components are sequenced and delayed for optimum space conditioning performance and to make any startup noise less noticeable.

Test Mode

The microprocessor control allows the technician to shorten most timing delays for faster diagnostics by changing the position of a jumper located on the lockout board.

Water Solenoid Valve Connections

Two accessory relay outputs at the terminal strip provide a field connection for two types of water solenoid valves, a standard 24VAC solenoid valve, or a 24VAC solenoid valve with an end switch. Additional field wiring is no longer required for operation of the end switch.

Humidifier/Dehumidification Connections

Connections for a humidistat are provided, which automatically engages the fan when the humidistat contact closes. In addition, a field connection is provided at the terminal strip for external control of the On Demand Dehumidification (ODD) feature for the variable speed ECM motor (when equipped), which automatically lowers the fan speed when the space humidity is higher than set point. Either connection may be used with a thermostat that includes humidifier/dehumidification outputs. Not applicable for splits/water-to-water.

Airflow Monitor (Units with ECM Motor)

An LED on the ECM control module flashes one time per 100 CFM when the unit's fan is operating to indicate airflow.

Resistance Heat Control

The electric heat control module contains the appropriate high-voltage control relays. Low voltage control signals from the compressor section energize the relays in the electric heat module to engage backup electric heat when necessary.

Electronic Condensate Overflow Protection

The control board utilizes an impedance sensing liquid sensor at the top of the drain pan. Since the drain pan is grounded, when water touches the sensor for 30 continuous seconds, the sensor sends a ground signal to the lockout board, indicating that a condensate overflow fault has occurred.

Section 11a: Controls

Figure 13: ECM Board Layout

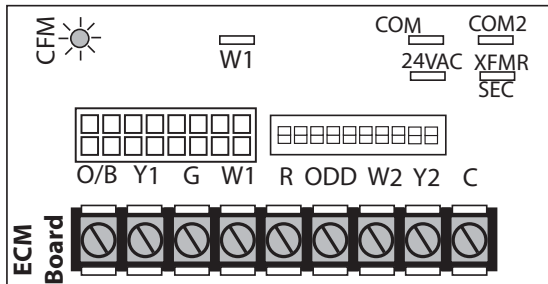

Loop Pump Circuit Breakers (Single Compressor Units)

The loop pump(s) and desuperheater pump are protected by control box mounted circuit breakers for easy wiring of pumps during installation. Circuit breakers eliminate the need to replace fuses.

Safety Controls

The control receives separate signals for high pressure, low pressure, low water flow, and condensate overflow faults. Upon a continuous 30-second measurement of the fault (immediate for high pressure), compressor operation is suspended (see Fault Retry below), and the appropriate LED flashes. Once the unit is locked out (see Fault Retry below), an output (terminal "L") is made available to a fault LED at the thermostat (water-to-water unit has fault LED on the corner post).

Low Pressure: If the low pressure switch is open for 30 continuous seconds, the compressor operation will be interrupted, and the control will go into fault retry mode. At startup, the low pressure switch is not monitored for 90 seconds to avoid nuisance faults.

High Pressure: If the high pressure switch opens, the compressor operation will be interrupted, and the control will go into fault retry mode. There is no delay from the time the switch opens and the board goes into fault retry mode. There is also no delay of switch monitoring at startup.

Flow Switch: If the flow switch is open for 30 continuous seconds, the compressor operation will be interrupted, and the control will go into fault retry mode. At startup, the flow switch is not monitored for 30 seconds to avoid nuisance faults.

Condensate Overflow: If water touches the condensate overflow sensor for 30 continuous seconds, the compressor operation will be interrupted, and the control will go into fault retry mode. There is no delay of switch monitoring at startup.

FAULT RETRY

All faults are retried twice before finally locking the unit out. The fault retry feature is designed to prevent nuisance service calls. There is an anti-short cycle period between fault retries. On the third fault, the board will go into lockout mode.

Over/Under Voltage Shutdown

The lockout board protects the compressor from operating when an over/under voltage condition exists. The control monitors secondary voltage (24VAC) to determine if an over/under voltage condition is occurring on the primary side of the transformer. For example, if the secondary voltage is 19 VAC, the primary voltage for a 240V unit would be approximately 190V, which is below the minimum voltage (197V) recommended by the compressor manufacturer. This feature is self-resetting. If the voltage comes back within range, normal operation is restored. Therefore, over/under voltage is not a lockout.

Under voltage (18 VAC) causes the compressor to disengage and restart when the voltage returns to 20 VAC. Over voltage (31 VAC) causes the compressor to disengage and restart when the voltage returns to 29 VAC. During an over or under voltage condition, all five fault LEDs will blink (HP + LP + FS + CO + Status). When voltage returns to normal operation, the four fault LED's will stop blinking, but the status LED will continue to flash. While the board LEDs are flashing, the thermostat fault light will be illuminated.

Section 11a: Controls

Intelligent Reset

If the thermostat is powered off and back on (soft reset), the board will reset, but the last fault will be stored in memory for ease of troubleshooting. If power is interrupted to the board, the fault memory will be cleared.

Lockout with Emergency Heat

While in lockout mode, if the thermostat is calling for backup heat, emergency heat mode will occur.

Diagnostics

The lockout board includes five LEDs (status, high pressure, low pressure, low water flow, condensate overflow) for fast and simple control board diagnosis. Below is a table showing LED function.

Table 6: LED Identification

LED Color	Location ¹	Function	Normal Operation	Fault Retry ²	Lockout ²
Green	Top	High Pressure	OFF	Flashing ³	ON ³
Orange	2nd	Low Pressure	OFF	Flashing ³	ON ³
Red	3rd	Water Flow	OFF	Flashing ³	ON ³
Yellow	4th	Condensate Overflow	OFF	Flashing ³	ON ³
Green	Bottom	Status	Flashing ⁴	Flashing ⁵	Flashing ⁴

Notes:

1. Looking at the board when the LEDs are on the right hand side.
2. If all five lights are flashing, the fault is over/under voltage.
3. Only the light associated with the particular fault/lockout will be on or flashing.
For example, if a high pressure lockout has occurred, the top green light will be on. The orange, red, and yellow lights will be off.
4. Status lights will be off when in test mode.
5. Flashes alternately with the fault LED.

Hot Water Pump Control

Controls for high water temperature and low compressor discharge line temperature prevent the hot water (desuperheater) pump from operating when the leaving water temperature is above 130°F, or when the compressor discharge line is too cool to provide adequate water heating.

Lockout Board Jumper Selection

The lockout board includes three jumpers for field selection of various board features.

Water Solenoid Valve Delay (WSD): When the WSD jumper is installed, the "A" terminal is energized when the compressor is energized. When the jumper is removed, the "A" terminal is energized 10 seconds after the compressor. If using the Taco water solenoid valve (or a valve with an end switch), the unit terminal strip includes a means for connecting a valve of this type. The WSD jumper should be installed. If

using a fast opening valve that does not have an end switch, the jumper should be removed.

Test Mode (TEST): When the TEST jumper is installed, the board operates in the normal mode. When the jumper is removed, the board operates in test mode, which speeds up all delays for easier troubleshooting. When service is complete, the jumper must be re-installed in order to make sure that the unit operates with normal sequencing delays.

Over/Under Voltage Disable (O/V): When the O/V jumper is installed, the over/under voltage feature is active. When the jumper is removed, the over/under voltage feature is disabled. On rare occasions, variations in voltage will be outside the range of the over/under voltage feature, which may require removal of the jumper. However, removal of the jumper could cause the unit to run under adverse conditions, and therefore should not be removed without contacting technical services. An over/under

Section 11a: Controls

voltage condition could cause premature component failure or damage to the unit controls. Any condition that would cause this fault must be thoroughly investigated before taking any action regarding the jumper removal. Likely causes of an over/under voltage condition include power company transformer selection, insufficient entrance wire sizing, defective breaker panel, incorrect transformer tap (unit control box), or other power-related issues.

SEQUENCE OF OPERATION:

Water-to-Air Units, Single Compressor, ECM Fan

Heating, 1st Stage (Y1,G) Two-Stage Units

The ECM fan is started immediately at 75% (of 1st stage operation) CFM level (based on DIP switch settings), first stage compressor and the loop/desuperheater pump(s) are energized 10 seconds after the "Y1" input is received, and the ECM fan adjusts to 100% (of 1st stage operation) CFM level 30 seconds after the "Y1" input.

Heating, 2nd Stage (Y1,Y2,G) Two-Stage Units

The ECM fan adjusts to 2nd stage CFM level (based on DIP switch settings), and the compressor full load solenoid valve is energized.

Heat, 3rd Stage (Y1,Y2,W,G) Two-Stage Units

The ECM fan remains at 100% of 2nd stage CFM level (based on DIP switch settings), and the electric backup heat is energized.

Emergency Heat (W,G)

The fan is started immediately at 2nd stage CFM level (based on DIP switch settings), and the electric backup heat is energized.

Cooling Operation

The reversing valve is energized for cooling operation. Terminal "O" from the thermostat is connected to the reversing valve solenoid.

Cooling, 1st stage (Y1,O,G) Two-Stage Units

The ECM fan is started immediately at 75% (of 1st stage operation) CFM level (based on DIP switch settings), first stage compressor and the loop/desuperheater pump(s) are energized 10 seconds after the "Y1" input is received, and the ECM fan adjusts to 100% (of 1st stage operation) CFM level 30 seconds after the "Y1" input.

Figure 14: Lockout Board Layout

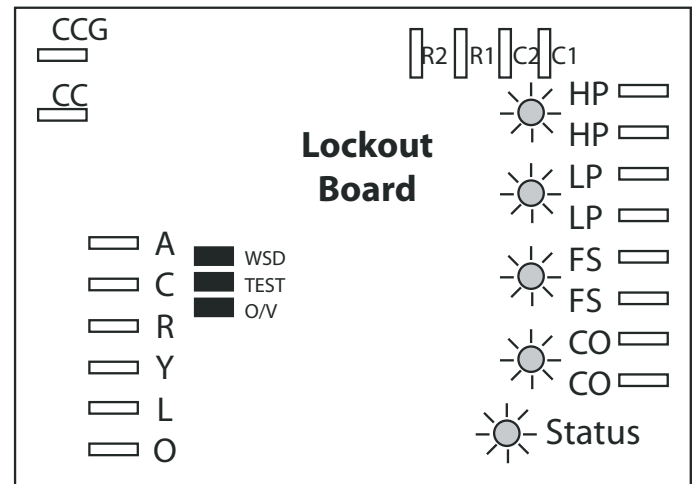

Cooling, 2nd Stage (Y1,Y2,O,G) Two-Stage Units

The ECM fan adjusts to 2nd stage CFM level (based on DIP switch settings), and the compressor full load solenoid valve is energized.

Cooling, Dehumidification Mode

The ECM control module includes two types of dehumidification modes, Forced Dehumidification mode, and On Demand Dehumidification (ODD). If the ECM control module is set to Forced Dehumidification mode, the ECM fan runs at normal CFM in all heating stages, but all cooling operation will be 85% of the current stage CFM level (based on DIP switch settings), which lowers the CFM through the evaporator coil, improving latent capacity. In ODD mode, a humidistat or a thermostat with a dehumidification output (output must be reverse logic -- i.e. it must operate like a humidistat) is connected to the ODD terminal. When the module receives a call for dehumidification, the fan runs at 85% of the current stage CFM in the cooling mode. Otherwise, the airflow is at the normal CFM level. The signal is ignored in the heating mode.

Fan Only

When the ECM control module receives a "G" call without a call for heating or cooling, the fan operates at 50% of the full load CFM level (based on DIP switch settings).

Section 11a: Controls

Table 7: ECM Fan Performance - Two-Stage Compressor Units

ECM Fan Performance - Two-Stage Compressor Units

Model ¹	Program ²	Heating Modes		Cooling Modes		Dehumidification Mode ⁶		Only Fan	DIP Switch Settings ⁴							
		1st Stage	2nd Stage	1st Stage	2nd Stage	1st Stage	2nd Stage		S1	S2	S3	S4	S5	S6	S7	S8
024	A	800	1050	800	1000	680	850	500	ON	OFF	ON	OFF	ON	OFF	OFF	OFF
	B	700	950	700	950	595	808	450	ON	OFF	OFF	OFF	ON	OFF	OFF	OFF
	C	650	825	650	800			400	ON	OFF	OFF	ON	ON	OFF	OFF	OFF
	D	600	750	600	750			375	OFF	ON	OFF	OFF	OFF	ON	OFF	OFF
036	A	-	-	-	-	-	-	-	-	-	-	-	-	-	-	-
	B	1050	1300	1050	1300	893	1105	650	OFF	OFF	ON	OFF	OFF	OFF	OFF	OFF
	C	900	1200	900	1200	765	1020	600	OFF	OFF	OFF	OFF	OFF	OFF	OFF	OFF
	D	850	1050	850	1050			525	OFF	OFF	OFF	ON	OFF	OFF	OFF	OFF
048	A	1500	1750	1550	1850	1318	1573	925	ON	OFF	ON	OFF	ON	OFF	OFF	OFF
	B	1400	1650	1400	1700	1190	1445	850	OFF	ON	ON	OFF	OFF	ON	OFF	OFF
	C	1275	1500	1275	1550			775	OFF	ON	OFF	OFF	OFF	ON	OFF	OFF
	D	1150	1350	1150	1400			700	OFF	ON	OFF	ON	OFF	ON	OFF	OFF
060	A	1800	2150	1750	2100	1488	1785	1050	OFF	OFF	ON	OFF	OFF	OFF	OFF	OFF
	B	1500	1750	1550	1850	1318	1573	925	ON	OFF	ON	OFF	ON	OFF	OFF	OFF
	C	1350	1600	1400	1675			840	ON	OFF	OFF	OFF	ON	OFF	OFF	OFF
	D	1225	1425	1250	1500			750	ON	OFF	OFF	ON	ON	OFF	OFF	OFF
072	A	-	-	-	-	-	-	-	-	-	-	-	-	-	-	-
	B	1800	2150	1750	2100	1488	1785	1050	OFF	OFF	ON	OFF	OFF	OFF	OFF	OFF
	C	1625	1950	1600	1900	1360	1615	950	OFF	OFF	OFF	OFF	OFF	OFF	OFF	OFF
	D	1475	1750	1425	1700			850	OFF	OFF	OFF	ON	OFF	OFF	OFF	OFF

Notes:

1. Program B (Bold type) is factory settings and rated CFM. CFM is controlled within 5% up to the max. ESP. Max. ESP includes allowance for wet coil and standard filter.
2. Power must be off to the unit for at least 3 seconds before the ECM motor will recognize a speed change.
3. Models 036 can maintain above CFM up to 0.5" ESP; Models 048 - 072 can maintain above CFM up to 0.75" ESP.

Dehumidification Mode Options

DIP Switch		Mode	Operation
S9	S10		
ON	OFF	Normal	Dehumidification mode disabled (normal Htg/Clg CFM) - factory setting
OFF	ON	ODD	On Demand dehumidification mode (humidistat input at terminal ODD) - Humidistat required
OFF	OFF	Constant Dehum	Constant dehumidification mode (always uses dehum CFM for cooling and normal CFM for heating) - No humidistat required
ON	ON	Not Used	Not an applicable selection

Notes:

1. ODD uses reverse logic, which allows a humidistat to be used for this feature instead of a dehumidistat. To enter dehumidification mode, ODD input should be 0 VAC; for normal cooling CFM, ODD input should be 24VAC.
2. Heating CFM is not affected by dehumidification mode. When in dehumidification mode, cooling CFM is 85% of normal cooling CFM (when not in dehumidification mode).

Section 11a: Controls

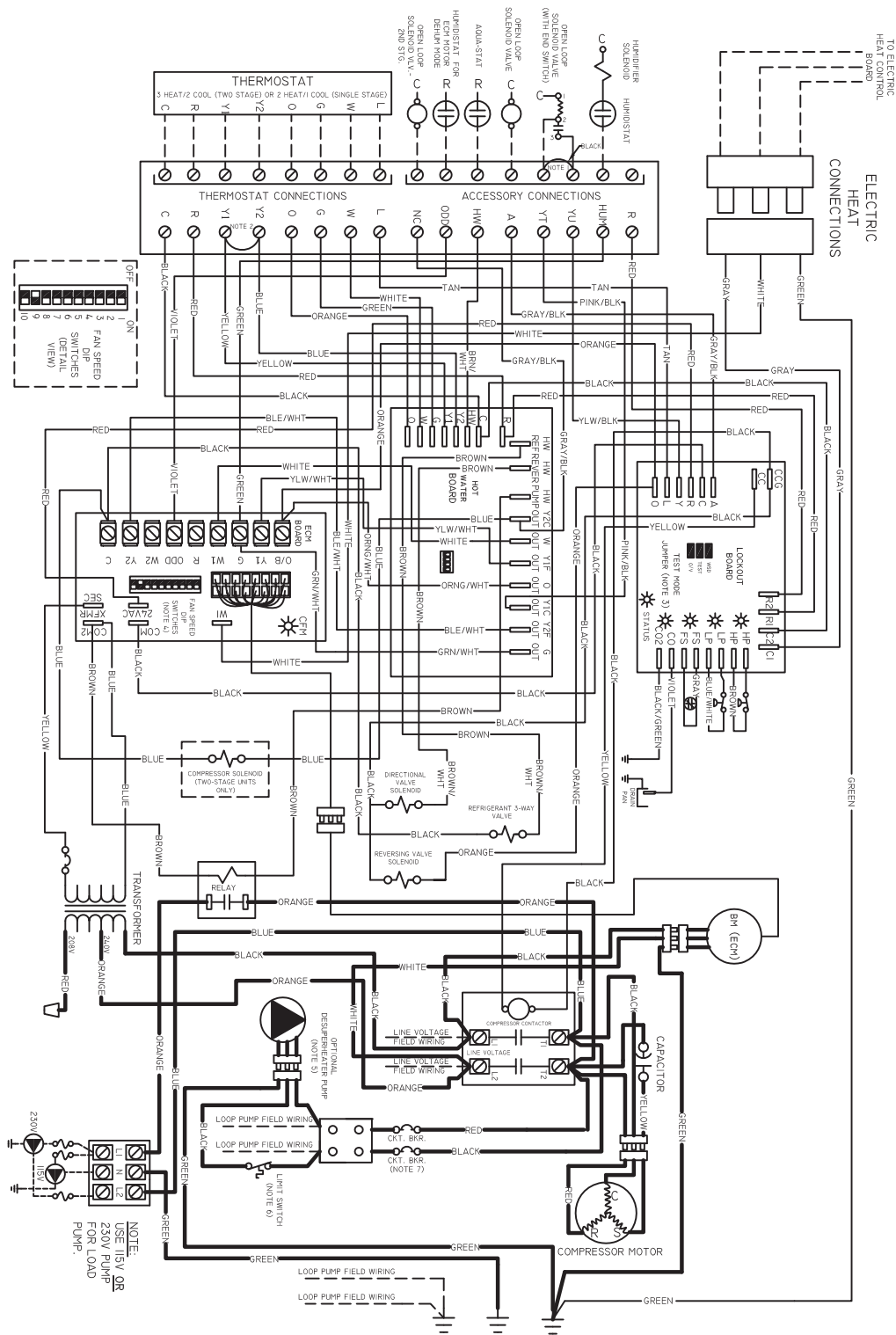

NOTES:

1. FACTORY INSTALLED JUMPER. REMOVE FOR USE WITH SOLENOID VALVE WITH END SWITCH.
2. FACTORY INSTALLED JUMPER FOR SINGLE STAGE UNITS.
3. JUMPER INSTALLED-NORMAL; JUMPER REMOVED-TEST.
4. SEE CFM CHART FOR DIP SWITCH CHOICES BY MODEL.
5. DESUPERHEAT PUMP POWER QUICK DISCONNECT HARNESS IS NOT CONNECTED AT THE FACTORY. DO NOT CONNECT WIRES UNTIL THE PIPING IS COMPLETED AND PURGED OF AIR. RUNNING THE PUMP WITHOUT WATER WILL DAMAGE THE PUMP.
6. DESUPERHEATER LEAVING WATER TEMPERATURE SWITCH WILL DISENGAGE THE PUMP WHEN CONDITIONS ARE INAPPROPRIATE FOR WATER HEATING.
7. CIRCUIT BREAKERS ARE INSTALLED ON RESIDENTIAL MODELS ONLY.

Section 11b: Combination Unit Controls

COMBINATION UNIT CONTROLS

The hot water (combination unit) control board prioritizes unit operation even when there are simultaneous calls from the thermostat and aqua-stat. Inputs to the board include thermostat signals as well as an aqua-stat input. The hot water board acts as a "traffic director," since all inputs are sent to the hot water board first. Then, based upon priority selection, signals are directed to the lockout board, hot water mode outputs (pump relay, direction valve, 3-way valve), and/or the ECM control board. If there is a simultaneous heating and hot water call, by default, hot water will take priority. Hot water priority DIP switches will allow the choice of four priority modes (see below).

In default (hot water) mode, any time there is an input from the aqua-stat, water heating is priority. If there is a call from the thermostat for reversing valve ("O"), the call will be ignored until the hot water call has been satisfied. If there is a simultaneous call for hot water and hot air ("Y1," "G," and "HW"), the thermostat inputs will be ignored. An "HW" call by itself will cause an output on "Y1C" to the lockout board, and an output to the hot water mode components (pump relay, direction valve, 3-way valve) on terminal "HW."

PRIORITY SELECTION

Priority selections are defined as follows:

- Hot water priority (default mode): In hot water priority mode, the aqua-stat input always takes priority, regardless of the thermostat inputs. Once the hot water call is satisfied, and there is still a thermostat call, the unit attempts to satisfy the thermostat call.
- Hot water priority with electric heat: In hot water priority with electric heat mode, the aqua-stat input always takes priority, regardless of the thermostat inputs. However, if there is a simultaneous thermostat call for heating (reversing valve is not energized), the control will energize the fan and electric heat outputs, allowing electric heat to satisfy the thermostat call. Once the hot water call is satisfied, and there is still a thermostat call, the unit will then attempt to satisfy the thermostat call after a five-minute anti-short cycle timer with normal forced air (i.e. compressor) mode, and the thermostat inputs will determine operating mode.

- Forced air priority: In forced air priority mode, the thermostat input always takes priority, regardless of the aqua-stat input. Once the thermostat call is satisfied, and there is still an aqua-stat call, the unit attempts to satisfy the hot water call after a five-minute anti-short cycle timer.
- Shared priority: In shared priority mode, the unit operates in the hot water priority mode and in forced air priority mode in an alternating sequence. There is a field selectable timer, which will allow settings of 20, 30, or 40 minutes for switch over time. The unit will always start in hot water priority mode at the first call for hot water (aqua-stat input). Then, based upon the timer setting, the unit will switch to forced air priority for the selected amount of time. For example, if the timer is set for 20 minutes, and the unit has a simultaneous call for hot water and thermostat, after 20 minutes of hot water operation, the control will switch over to forced air priority for 20 minutes, and then switch back to hot water priority for 20 minutes, and so on. If the aqua-stat call is satisfied, forced air operation is allowed at any time; likewise if the thermostat is satisfied, hot water operation is allowed at any time. There is a five-minute anti-short cycle timer between modes.

Figure 17: Combination Unit Control Board

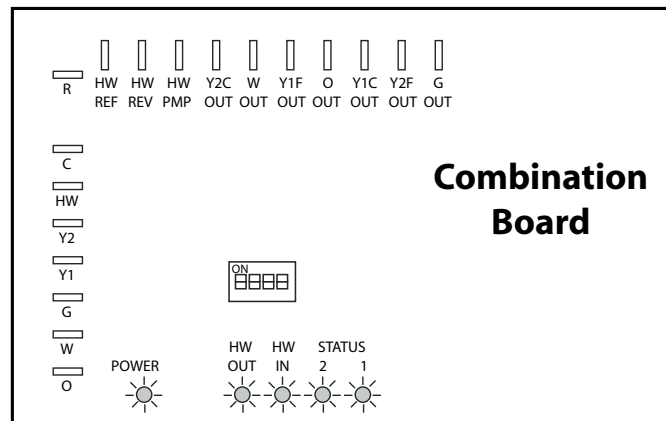

Section 11b: Combination Unit Controls

Table 10: Combination Controls DIP Switch Settings

Operation Mode	Fan Mode	DIP Switch			
		1	2	3	4
Hot Water Priority	Fan OFF during HW mode regardless of 'G'	ON	OFF	OFF	ON
Hot Water Priority with Electric Heat	Fan OFF in HW mode except in Elec Ht oper	OFF	ON	OFF	ON
Forced air Priority	Fan OFF during HW mode regardless of 'G'	ON	ON	OFF	ON
Shared Priority (check every 20 min)	Fan OFF during HW mode regardless of 'G'	OFF	OFF	ON	ON
Shared Priority (check every 30 min)	Fan OFF during HW mode regardless of 'G'	ON	OFF	ON	ON
Shared Priority (check every 40 min)	Fan OFF during HW mode regardless of 'G'	OFF	ON	ON	ON
Hot Water Priority	Fan every time there is a 'G' call	ON	OFF	OFF	OFF
Hot Water Priority with Electric Heat	Fan every time there is a 'G' call	OFF	ON	OFF	OFF
Forced air Priority	Fan every time there is a 'G' call	ON	ON	OFF	OFF
Shared Priority (check every 20 min)	Fan every time there is a 'G' call	OFF	OFF	ON	OFF
Shared Priority (check every 30 min)	Fan every time there is a 'G' call	ON	OFF	ON	OFF
Shared Priority (check every 40 min)	Fan every time there is a 'G' call	OFF	ON	ON	OFF

Factory settings are ON/OFF/OFF/ON

Section 11b: Combination Unit Controls

OUTPUT CONTROL

The hot water board sends output to the lockout and/or ECM control boards based upon the priority selections above and current operation mode. The board controls the following outputs:

- Compressor control:** If there is a "Y1" call from the thermostat and not an "HW" call, the "Y1" signal will be passed directly through the board to the lock-out board. Otherwise, the priority modes (above) will determine how the compressor is controlled. In all priority modes, there will be a compressor off time of 5 minutes to allow the refrigerant circuit to equalize. For example, if the unit is in hot water priority mode, and the current operation is forced air heating (thermostat input), when the aqua-stat calls for heating, the lockout board will stop the compressor for 5 minutes regardless of the outputs from the hot water board.
- Fan control:** DIP switch #4 (see above table) will allow or disallow fan operation during hot water operation when there is a "G" input from the thermostat. If there is an aqua-stat call and a thermostat call, the board will control the fan output based upon priority. For example, if the board is set for "Hot Water Priority," and the fan control is set for "Fan OFF except in Hot Water Priority with Electric Heat", the board will ignore all thermostat inputs (including the "G" input) until the aqua-stat is satisfied. If continuous fan is desired, DIP switch #4 should be in the OFF position.
- Second stage operation:** When in hot water mode, the compressor will be operated in full load (Y2). During water-to-air operation, the compressor may operate in full or part load, depending upon the thermostat call.
- Reversing valve control:** If there is a call for cooling and not a call for hot water, the "O" signal will be passed through the board to the reversing valve solenoid. Otherwise, the priority modes (above) will determine how the reversing valve is controlled. At no time will the unit provide chilled water. Operating modes are forced air heating, forced air cooling, and hot water mode

Table 11: LED Indicators

The board includes five LEDs with the following operation:

- Power LED (Green):** Indicates that the board has 24 VAC.
- HW IN LED (Yellow):** Indicates that the aqua-stat is calling for hot water.
- HW OUT LED (Amber):** Indicates that the board has energized the hot water mode components (compressor, pump relay, direction valve, 3-way valve).
- Status lights (two - red and green):** see table below.

Mode	Power LED (Green)	Hot Water LEDs		Status lights	
		HW OUT (Amber)	HW IN (Yellow)	LED 2 (Red)	LED 1 (Green)
Heating stage 1	ON	OFF	1	ON	1 flash
Heating stage 2	ON	OFF	1	ON	2 flashes
Heating stage 3	ON	OFF	1	ON	3 flashes
Emergency heat	ON	OFF	2	ON	4 flashes
Cooling stage 1	ON	OFF	1,3	1 flash	ON
Cooling stage 2	ON	OFF	1,3	2 flashes	ON
Hot water mode	ON	ON	ON	1 flash	1 flash
Hot wtr mode w/elec ht	ON	ON	ON	2 flashes	2 flashes
Fan only	ON	OFF	OFF	ON	ON

1 HW IN (aqua-stat call) could be ON or OFF, depending upon priority selection and current state of hot water buffer tank.

2 Unless manually selected, emergency heat should only be used when the unit is locked out. The HW IN (aqua-stat call) would probably be ON in the case of a unit lock out in the heating mode.

3 If the hot water mode is used for radiant floor or other hydronic heating applications, there would normally not be a HW IN (aqua-stat call) in the cooling mode.

Section 11b: Combination Unit Controls

SEQUENCE OF OPERATION:

Combination Units

Heating, 1st Stage (Y1,G) Two-Stage Units

The ECM fan is started immediately at 75% (of 1st stage operation) CFM level, first stage compressor and the loop/desuperheater pump(s) are energized 10 seconds after the "Y1" input is received. The ECM fan adjusts to 100% (of 1st stage operation) CFM level 30 seconds after the "Y1" input.

Heating, 2nd Stage (Y1,Y2,G) Two-Stage Units

The ECM fan adjusts to 2nd stage CFM level, and the compressor full load solenoid valve is energized 30 seconds after the "Y2" input is received.

Heat, 3rd Stage (Y1,Y2,W,G) Two-Stage Units

The ECM fan remains at 100% of 2nd stage CFM level, and the electric backup heat is energized.

Emergency Heat (W,G)

The fan is started immediately at 100% of 2nd stage CFM level, and the electric backup heat is energized.

Cooling Operation

The reversing valve is energized for cooling operation. Terminal "O" from the thermostat is connected to the reversing valve solenoid.

Cooling, 1st stage (Y1,O,G) Two-Stage Units

The ECM fan is started immediately at 75% (of 1st stage operation) CFM level, first stage compressor and the loop/desuperheater pump(s) are energized 10 seconds after the "Y1" input is received. The ECM fan adjusts to 100% (of 1st stage operation) CFM level 30 seconds after the "Y1" input.

Cooling, 2nd Stage (Y1,Y2,O,G) Two-Stage Units

The ECM fan adjusts to 2nd stage CFM level, and the compressor full load solenoid valve is energized 30 seconds after the "Y2" input is received.

Cooling, Dehumidification Mode

The ECM control module includes two types of dehumidification modes, Forced Dehumidification mode, and On Demand Dehumidification (ODD). If the ECM control module is set to Forced Dehumidification mode, the ECM fan runs at normal CFM in all heating stages, but all cooling operation will be 85% of the current stage CFM level, which lowers the CFM through the evaporator coil, improving latent capacity. In ODD mode, a humidistat or a thermostat with a dehumidification

output (output must be reverse logic -- i.e. it must operate like a humidistat) is connected to the ODD terminal. When the module receives a call for dehumidification, the fan runs at 85% of the current stage CFM in the cooling mode. Otherwise, the airflow is at the normal CFM level. The signal is ignored in the heating mode.

Fan Only

When the ECM control module receives a "G" call without a call for heating or cooling, the fan operates at 50% of the full load CFM level.

Hot Water Operation (HW)

First stage compressor, direction valve, 3-way valve, load pump relay, and loop/desuperheater pump(s) are energized 10 seconds after the Aqua-stat ("HW") input is received. The compressor full load solenoid valve is energized 30 seconds after the "HW" input is received. The compressor always runs in full load (2nd stage) in hot water mode. NOTE: Combination units can heat water, but do not have chilled water capability.

Time Delays When Switching Modes

In order for the direction valve and 3-way valve to switch properly, the system must have time for the refrigerant pressures to equalize. The combo board always initiates a two-minute delay when switching from forced air mode to the hot water mode to insure that the valves are not switched before the pressures have equalized. The lockout board initiates a five-minute anti-short cycle delay anytime the compressor signal is interrupted. For example, if the unit is running in forced air heating, and gets a call from the aqua-stat (when the board is in hot water priority mode), the combo board will de-energize the compressor. After two minutes, the combo board will re-energize the compressor relay, direction valve, and 3-way valve for hot water mode operation. Even though the combo board is calling for compressor, the lockout board still requires an additional 3 minutes before the compressor has been off for 5 minutes. Therefore, there will always be five minutes off time when switching mode

Section 12: Accessories

Table 9: Auxiliary Heater Electrical Data

TECHNICAL DATA (AHTR Electric Heaters only) Single Phase w/ Circuit Breaker												
Heater Model	Supply Voltage	Heat kW	Supply Circuit Number	Heater kW Per Circuit	FLA Total AMPS	MCA Min Circuit Ampacity	Maximum Over-Current Protective Device (AMPS.)	Recommended				
								Supply Wire 75°C. Copper			Ground Wire	
								# of Wires	Wire Size	Max Length (Ft)	# of wires	Min Size
AHTR101B	240	10	Single	5	41.7	52.1	60	2	6	101	1	10
	208	7.5	Single	3.75	36.1	45.1		2	6	115	1	10
AHTR151B	240	15	Mult. 1	5	20.8	26.0	30	2	10	118	1	10
			Mult. 2	10	41.7	52.1	60	2	6	101	1	10
	208	11.25	Mult. 1	3.75	18.0	22.5	30	2	10	118	1	10
			Mult. 2	7.5	36.1	45.1	60	2	6	101	1	10
AHTR201B	240	20	Mult. 1	10	41.6	52.0	60	2	6	101	1	10
			Mult. 2	10	41.6	52.0	60	2	6	101	1	10
	208	15	Mult. 1	7.5	48.1	60.0	60	2	6	101	1	10
			Mult. 2	7.5	48.1	60.0	60	2	6	101	1	10

Figure 15: Auxiliary Heater Placement

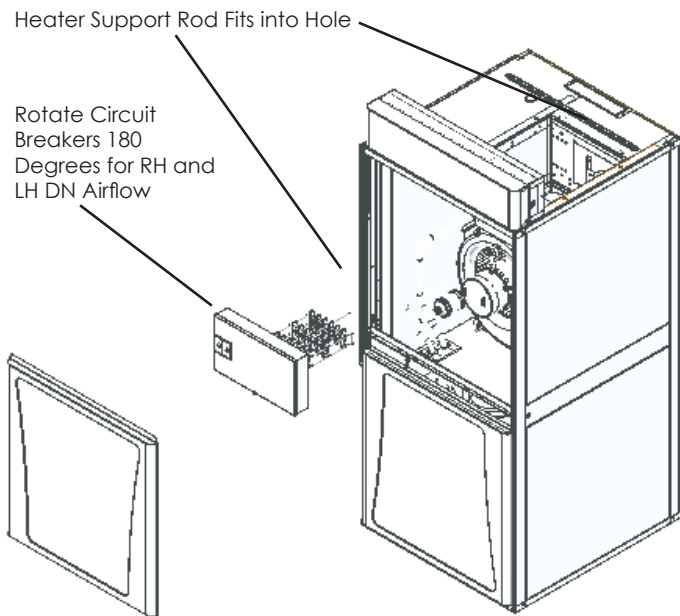

Representative drawing only, some models may vary in appearance.

APSMA PUMP SHARING MODULE

The pump sharing module, part number APSMA, is designed to allow two units to share one flow center. With the APSMA module, either unit can energize the pump(s). Connect the units and flow center as shown in Figure 16, below. Figure 17 includes a schematic of the board. The module must be mounted in a NEMA enclosure or inside the unit control box. Local code supersedes any recommendations in this document.

Installing Electric Heater High Voltage Wires:

All wiring **MUST** be done in strict compliance with local, state, national or any other applicable codes.

Note: If Electric Auxiliary is used, never disconnect power to the heat unit as it may be required to properly heat the home. Major damage may result.

Please note, these heaters are for vertical units only. Please see the Field-Installed Electric Heat IOM, part number 27P009-01NN for detailed instructions on the installation and wiring of auxiliary electric heaters.

Figure 16: APSMA Module Layout

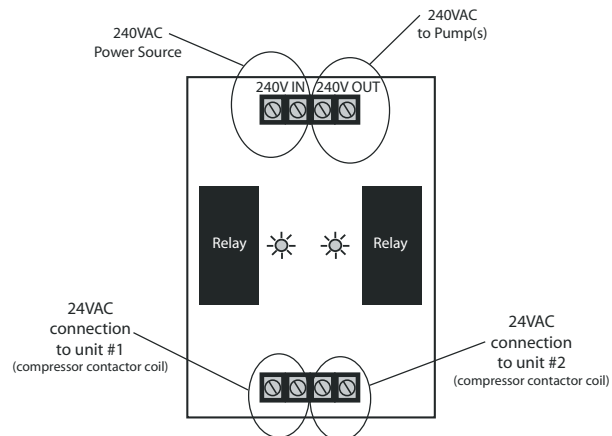
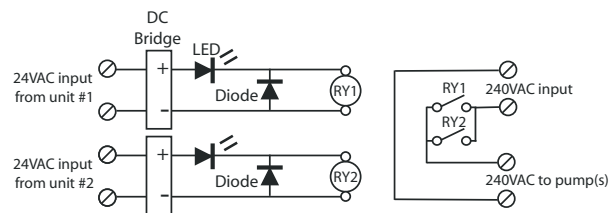

Figure 17: APSMA Module Wiring Schematic



Section 13: Troubleshooting

Table 10: Unit Heat of Extraction/Rejection Data (Full Load)

Two-Stage Water-to-Air Packaged Units (70°F EAT Heating; 80/67°F EAT Cooling)											
Heat of Extraction/Rejection-Full Load Operation (Mbtuh) -- DSP Disconnected											
EWT	Flow Rate	024		036		048		060		072	
°F	GPM/Ton	HE	HR	HE	HR	HE	HR	HE	HR	HE	HR
30	1.5	Future Model		18.6		24.6		31.4		37.6	
	2.25			21.0		25.9		33.2		41.0	
	3			21.4		27.6		34.0		41.4	
50	1.5			25.1	48.6	36.0	63.6	42.3	80.8	50.5	86.9
	2.25			28.1	49.1	37.8	63.6	44.6	81.2	54.6	88.6
	3			28.7	49.0	40.1	63.9	45.6	81.8	55.3	89.7
70	1.5			31.3	47.0	45.5	61.0	53.1	77.1	64.3	82.8
	2.25			35.1	47.3	47.8	61.0	56.0	77.3	69.4	84.2
	3			35.8	47.2	50.6	61.2	57.2	77.7	70.2	85.1
90	1.5			37.6	44.8	50.3	58.0	63.2	73.1	79.4	79.8
	2.25			42.0	45.1	52.9	57.9	66.5	73.1	85.7	80.9
	3			43.0	44.9	56.1	57.9	67.9	73.4	86.6	81.6
110	1.5			41.8		54.9		69.2		75.4	
	2.25			41.9		54.6		69.0		76.0	
	3			41.6		54.6		69.2		76.6	

NOTE: Always check HE or HR in Full Load Operation with desuperheater disconnected.

Section 13: Troubleshooting

Table 12: Two-Stage Unit Heat Exchanger Pressure Drop (Full Load)

Two-Stage Water-to-Air Packaged Units						
Heat Exchanger Pressure Drop						
Full Load Operation		Pressure Drop at Entering Water Temp. Listed Below				
Model	Flow Rate GPM	30°F PSI	50°F PSI	70°F PSI	90°F PSI	110°F PSI
024	Future Model					
036	4.5	1.0	0.9	0.8	0.7	0.6
	7.0	2.5	2.2	1.9	1.7	1.5
	9.0	4.2	3.6	3.1	2.8	2.4
048	6.0	2.0	1.8	1.6	1.4	1.4
	9.0	4.6	4.0	3.5	3.3	3.1
	12.0	8.2	7.0	6.3	5.8	5.5
060	7.5	2.1	1.8	1.6	1.5	1.4
	11.5	4.9	4.2	3.7	3.4	3.3
	15.0	8.4	7.2	6.4	5.9	5.6
072	9.0	2.1	1.9	1.8	1.7	1.5
	14.0	5.0	4.7	4.4	4.2	3.7
	16.0	6.6	6.1	5.8	5.4	4.9

Table 13: Two-Stage Unit Heat Exchanger Pressure Drop (Part Load)

Two-Stage Water-to-Air Packaged Units						
Heat Exchanger Pressure Drop						
Part Load Operation		Pressure Drop at Entering Water Temp. Listed Below				
Model	Flow Rate GPM	30°F PSI	50°F PSI	70°F PSI	90°F PSI	110°F PSI
024	Future Model					
036	4.5	1.0	0.9	0.8	0.7	0.6
	7.0	2.5	2.2	1.9	1.7	1.5
	9.0	4.2	3.6	3.1	2.8	2.4
048	4.5	1.1	1.0	0.9	0.8	0.8
	7.0	2.8	2.4	2.1	2.0	1.9
	9.0	4.6	4.0	3.5	3.3	3.1
060	6.0	1.3	1.1	1.0	0.9	0.9
	10.0	3.7	3.2	2.8	2.6	2.5
	12.0	5.4	4.6	4.1	3.8	3.6
072	8.0	1.6	1.5	1.4	1.4	1.2
	10.0	2.6	2.4	2.3	2.1	1.9
	14.0	5.0	4.7	4.4	4.2	3.7

Section 13: Troubleshooting

Table 14: Unit Operating Pressures (R-410a)

Heating - Without Desuperheater							
EWT (°F)	GPM Per Ton	Discharge Pressure (PSIG)	Suction Pressure (PSIG)	Sub Cooling (°F)	Super Heat (°F)	Air Temperature Rise (°F-DB)	Water Temperature Drop (°F)
30	1.5	285-310	68-76	4-10	8-12	14-20	5-8
	3	290-315	70-80	4-10	8-12	16-22	3-6
50	1.5	315-345	100-110	6-12	9-14	22-28	7-10
	3	320-350	105-115	6-12	9-14	24-30	5-8
70	1.5	355-395	135-145	7-12	10-15	30-36	9-12
	3	360-390	140-150	7-12	10-15	32-38	7-10
Cooling - Without Desuperheater							
EWT (°F)	GPM Per Ton	Discharge Pressure (PSIG)	Suction Pressure (PSIG)	Sub Cooling (°F)	Super Heat (°F)	Air Temperature Drop (°F-DB)	Water Temperature Rise (°F)
50	1.5	220-235	120-130	10-16	12-20	20-26	19-23
	3	190-210	120-130	10-16	12-20	20-26	9-12
70	1.5	280-300	125-135	8-14	10-16	19-24	18-22
	3	250-270	125-135	8-14	10-16	19-24	9-12
90	1.5	360-380	130-145	8-14	10-14	18-22	17-21
	3	330-350	130-140	8-14	10-14	18-22	8-11

PERFORMANCE CHECK

Heat of Extraction(HE)/Rejection(HR)
Record information on the Unit Start-up Form

Equipment should be in operation for a minimum of 10 minutes in either mode – **WITH THE HOT WATER GENERATOR TURNED OFF.**

1. Determine flow rate in gallons per minute
 - a. Check entering water temperature
 - b. Check entering water pressure
 - c. Check leaving water pressure

Once this information is recorded, find corresponding entering water temperature column in Specification Manual for unit. Find pressure differential in PSI column in Spec Manual. Then read the GPM column in Spec Manual to determine flow in GPM.

2. Check leaving water temperature of unit.
FORMULA: [GPM x water temp diff, x 485 (antifreeze)] /500 (fresh water) = HE or HR in BTU/HR

A 10% variance from Spec Manual is allowed. Always use the same pressure gauge & temperature measuring device. Water flow must be in range of Specification Manual. If system has too much water flow, performance problems should be expected.

Section 13: Troubleshooting

A: UNIT WILL NOT START IN EITHER CYCLE

Thermostat	Set thermostat on heating and highest temperature setting. Unit should run. Set thermostat on cooling and lowest temperature setting. Unit should run. Set fan to On position. Fan should run. If unit does not run in any position, disconnect wires at heat pump terminal block and jump R, G, Y. Unit should run in heating. If unit runs, replace thermostat with correct thermostat only.
Loose or broken wires	Tighten or replace wires.
Blown Fuse/ Tripped Circuit Breakers	Check fuse size, replace fuse or reset circuit breaker. Check low voltage circuit breaker.
Low Voltage Circuit	Check 24 volt transformer. If burned out or less than 24 volt, replace. Before replacing, verify tap setting and correct if necessary.
Water Flow	If water flow is low (less than 1 GPM), unit will not start. Make sure Pump Module or solenoid valve is connected (see wiring diagram). Water has to flow through the heat exchanger in the right direction (see labels at water fitting connections) before the compressor can start. If water flow is at normal flow, use an ohmmeter to check if you get continuity at the flow switch. If no switch is open and flow is a normal flow, remove switch and check for stuck particles or bad switch.

B: BLOWER RUNS BUT COMPRESSOR WILL NOT START

Logic Board	Check if logic board is working properly. Check status light for fault. See board imprint for blink faults.
Flow Switch	Temporarily bypass flow switch until compressor starts. If compressor runs properly, check switch. If defective, replace. If switch is not defective, check for air in loop system. Make sure loop system is properly purged. Verify flow rate before changing switch.

C: BLOWER RUNS BUT COMPRESSOR SHORT CYCLES OR DOES NOT RUN

Wiring	Loose or broken wires. Tighten or replace wires. See A: Unit will not start in either cycle.
Blown Fuse	Check fuse size. Check unit nameplate for correct sizing. Replace fuse or reset circuit breaker. Check low voltage circuit breaker.
Flow Switch	Temporarily bypass flow switch for a couple seconds. If compressor runs properly, check switch. If defective, replace. If switch is not defective, check for air in loop system. Make sure loop system is properly purged. Verify flow rate before changing switch. .
No Water flow	See A: Unit will not start in either cycle.
High or low pressure switches	If heat pump is out on high or low-pressure cutout (lockout), check for faulty switches by jumping the high and low-pressure switches individually. If defective replace. Check airflow, filters, water flow, loss of refrigerant and ambient temperature. WARNING: Only allow compressor to run for a couple of seconds with the high pressure switch jumpered
Defective logic board relay	Jump or bypass relay. If defective, replace.
Defective capacitor	Check capacitor. If defective, replace.
Frozen Compressor	See charts O and P for compressor diagnostic. If compressor still doesn't run, replace it.
Low refrigerant charge	Check for leaks and fix leaks.

D: BLOWER FAILS TO START BUT COMPRESSOR ATTEMPTS TO START

Defective blower motor capacitor	Check capacitor. If defective, replace.
Defective blower motor relay	Check relay. If defective, replace.

E: NOISY BLOWER AND LOW AIR FLOW

Noisy Blower	Blower wheel contacting housing—Readjust. Foreign material inside housing—Clean housing. Loose duct work—Secure properly.
Broken belt	If defective, replace belt. Check pulleys. If bad, replace. Check bearings. If frozen, replace bearing.
Low air flow	Check speed setting, check nameplate or data manual for proper speed, and correct speed setting. Check for dirty air filter—Clean or replace; obstruction in system—Visually check. Balancing dampers closed, registers closed, leaks in ductwork. Repair. Ductwork too small. Resize ductwork.

F: UNIT RUNNING NORMAL, BUT SPACE TEMPERATURE IS UNSTABLE

Thermostat	Thermostat is getting a draft of cold or warm air. Make sure that the wall or hole used to run thermostat wire from the ceiling or basement is sealed, so no draft can come to the thermostat. Faulty Thermostat (Replace).
------------	--

Section 13: Troubleshooting

G: NO WATER FLOW

Pump Module	Make sure Pump Module is connected to the control box relay (check all electrical connections). For non-pressurized systems, check water level in Pump Module. If full of water, check pump. Close valve on the pump flanges and loosen pump. Take off pump and see if there is an obstruction in the pump. If pump is defective, replace. For pressurized systems, check loop pressure. Re-pressurize if necessary. May require re-flushing if there is air in the loop.
Solenoid valve	Make sure solenoid valve is connected. Check solenoid. If defective, replace.

H: IN HEATING OR COOLING MODE, UNIT OUTPUT IS LOW

Water	Water flow & temperature insufficient.
Airflow	Check speed setting, check nameplate or data manual for proper speed, and correct speed setting. Check for dirty air filter—Clean or replace. Restricted or leaky ductwork. Repair.
Refrigerant charge	Refrigerant charge low, causing inefficient operation. Make adjustments only after airflow and water flow are checked.
Reversing valve	Defective reversing valve can create bypass of refrigerant to suction side of compressor. Switch reversing valve to heating and cooling mode rapidly. If problem is not resolved, replace valve. Wrap the valve with a wet cloth and direct the heat away from the valve. Excessive heat can damage the valve. Always use dry nitrogen when brazing. Replace filter/drier any time the circuit is opened.

I: IN HEATING OR COOLING MODE, UNIT OUTPUT IS LOW

Heat pump will not cool but will heat. Heat pump will not heat but will cool.	Reversing valve does not shift. Check reversing valve wiring. If wired wrong, correct wiring. If reversing valve is stuck, replace valve. Wrap the valve with a wet cloth and direct the heat away from the valve. Excessive heat can damage the valve. Always use dry nitrogen when brazing. Replace filter/drier any time the circuit is opened.
Water heat exchanger	Check for high-pressure drop, or low temperature drop across the coil. It could be scaled. If scaled, clean with condenser coil cleaner.
System undersized	Recalculate conditioning load.

J: WATER HEAT EXCHANGER FREEZES IN HEATING MODE

Water flow	Low water flow. Increase flow. See F. No water flow.
Flow Switch	Check switch. If defective, replace.

K: EXCESSIVE HEAD PRESSURE IN COOLING MODE

Inadequate water flow	Low water flow, increase flow.
-----------------------	--------------------------------

L: EXCESSIVE HEAD PRESSURE IN HEATING MODE

Low air flow	See E: Noisy blower and low air flow.
--------------	---------------------------------------

M: AIR COIL FREEZES OVER IN COOLING MODE

Air flow	See E: Noisy blower and low air flow.
Blower motor	Motor not running or running too slow. Motor tripping off on overload. Check for overheated blower motor and tripped overload. Replace motor if defective.
Panels	Panels not in place.
Low air flow	See E: Noisy blower and low air flow.

N: WATER DRIPPING FROM UNIT

Unit not level	Level unit.
Condensation drain line plugged	Unplug condensation line.
Water sucking off the air coil in cooling mode	Too much airflow. Duct work not completely installed. If duct work is not completely installed, finish duct work. Check static pressure and compare with air flow chart in spec manual under specific models section. If ductwork is completely installed it may be necessary to reduce CFM.
Water sucking out of the drain pan	Install an EZ-Trap or P-Trap on the drain outlet so blower cannot suck air back through the drain outlet.

Section 13: Troubleshooting

O: COMPRESSOR WON'T START

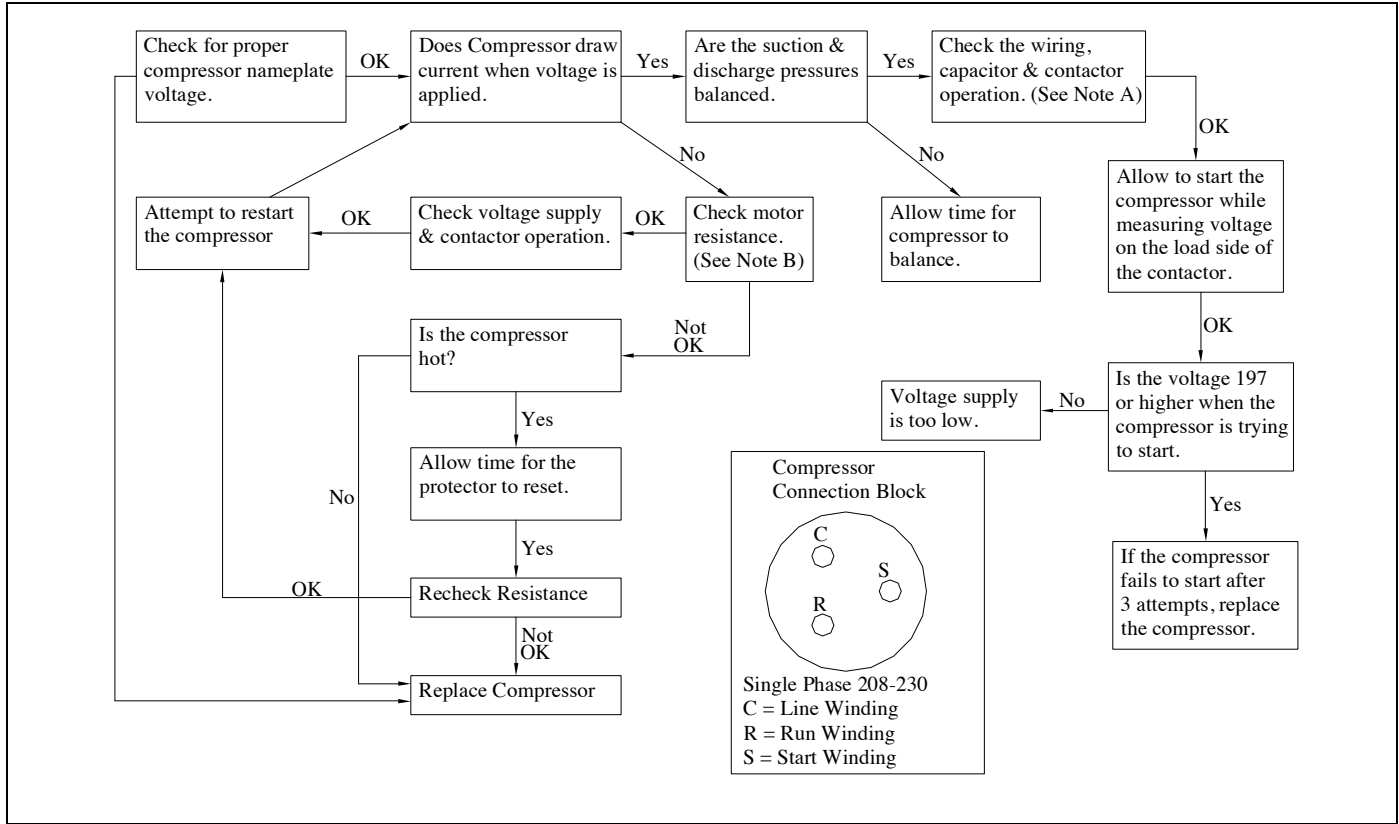

A: Check all terminals, wires & connections for loose or burned wires and connections. Check contactor and 24 Volt coil. Check capacitor connections & check capacitor with capacitor tester.

B: If ohm meter reads 0 (short) resistance from C to S, S to R, R to C or from anyone of one of these terminals to ground (shorted to ground), compressor is bad.

P: COMPRESSOR WON'T PUMP CHART

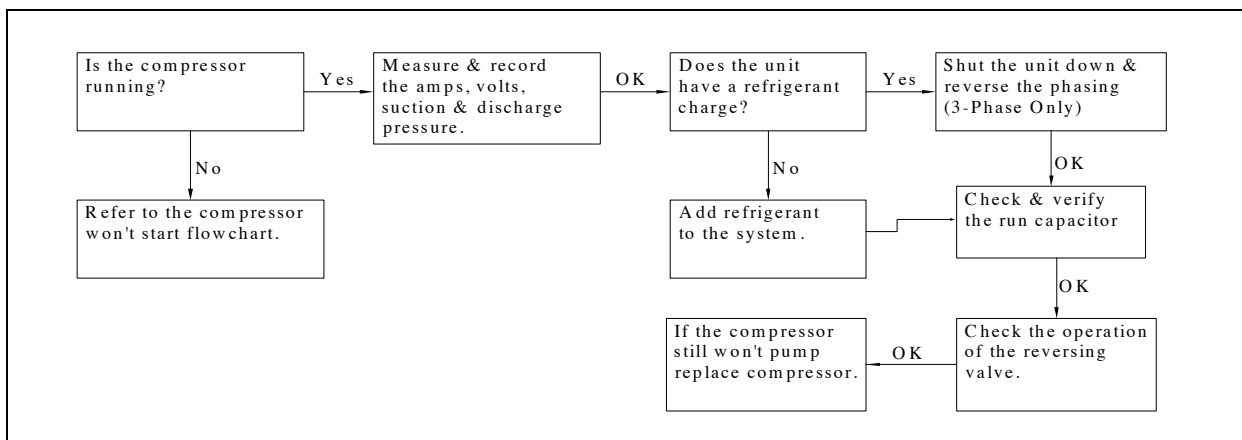

Section 13: Troubleshooting

Table 15: Refrigeration Troubleshooting

System Faults		Air Flow	Water Flow	Under Charge	Over Charge	Super Heat	Subcooling
Head Pressure Too High	Heat	P - Too Low			P		
	Cool		P - Too Low		P		
Head Pressure Too Low	Heat		P - Too Low	P		High	Low
	Cool	P - Too Low	S - Too High	P		High	Low
Suction Pressure Too High	Heat	P - Too Low					High
	Cool				P		High
Suction Pressure Too Low	Heat		P - Too Low	P		High	Low
	Cool	P - Too Low		P		High	Low
Liquid Refrigerant Flood Back	Heat				P		High
	Cool				P		High
Air Coil Frosting	Heat						
	Cool	P - Too Low		P		High	Low
Compressor Runs Inadequate. Or No Cooling/Heating	Heat	S - Too High	P - Too Low	P		High	Low
	Cool	S - Too High	P - Too Low	P		High	Low

P - Primary causes (most common problems) S - Secondary causes (problems that occur, but are not common)

Section 14: Forms - Troubleshooting

Customer/Job Name: _____ Date: _____

Model #: _____ Serial #: _____

Antifreeze Type: _____

$HE \text{ or } HR = GPM \times TD \times \text{Fluid Factor}$
 (Use 500 for water; 485 for antifreeze)

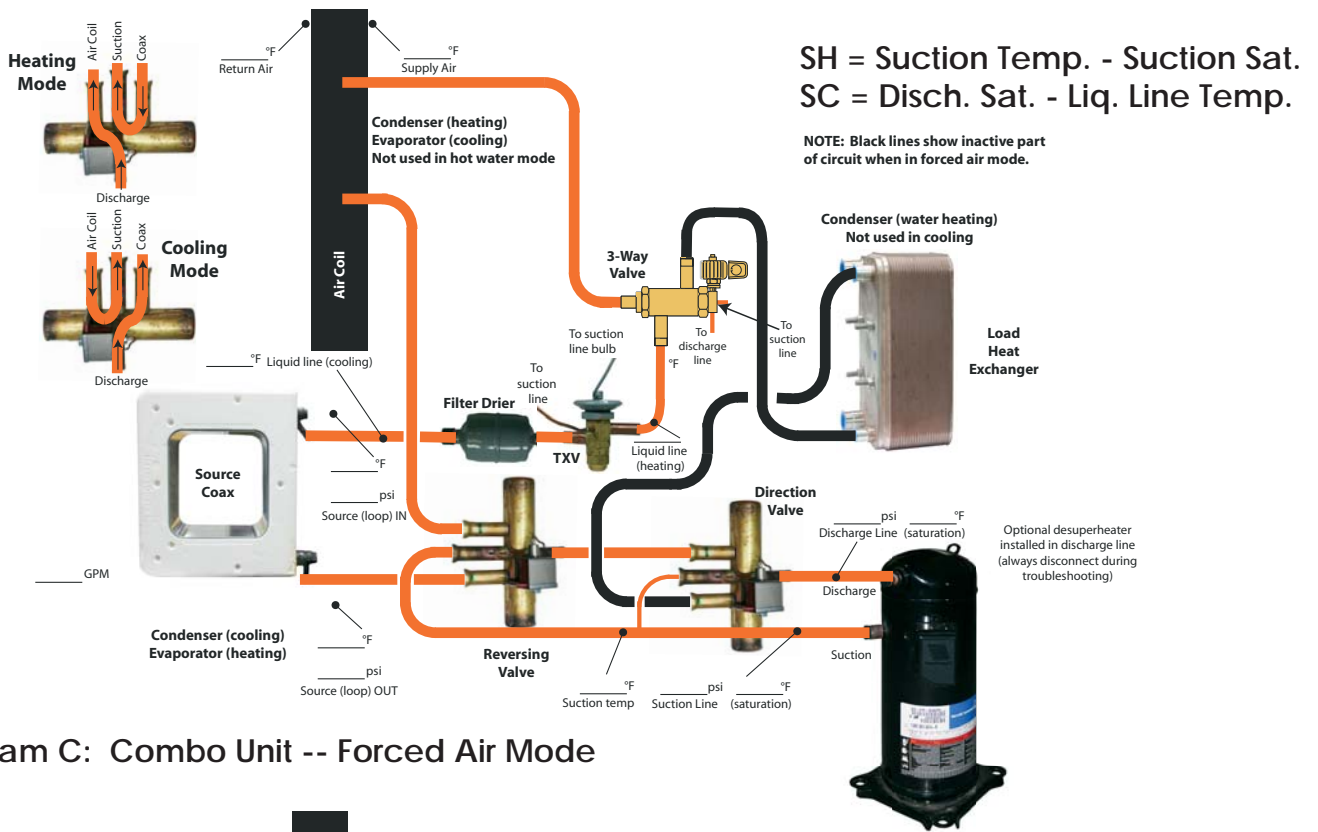

Diagram C: Combo Unit -- Forced Air Mode

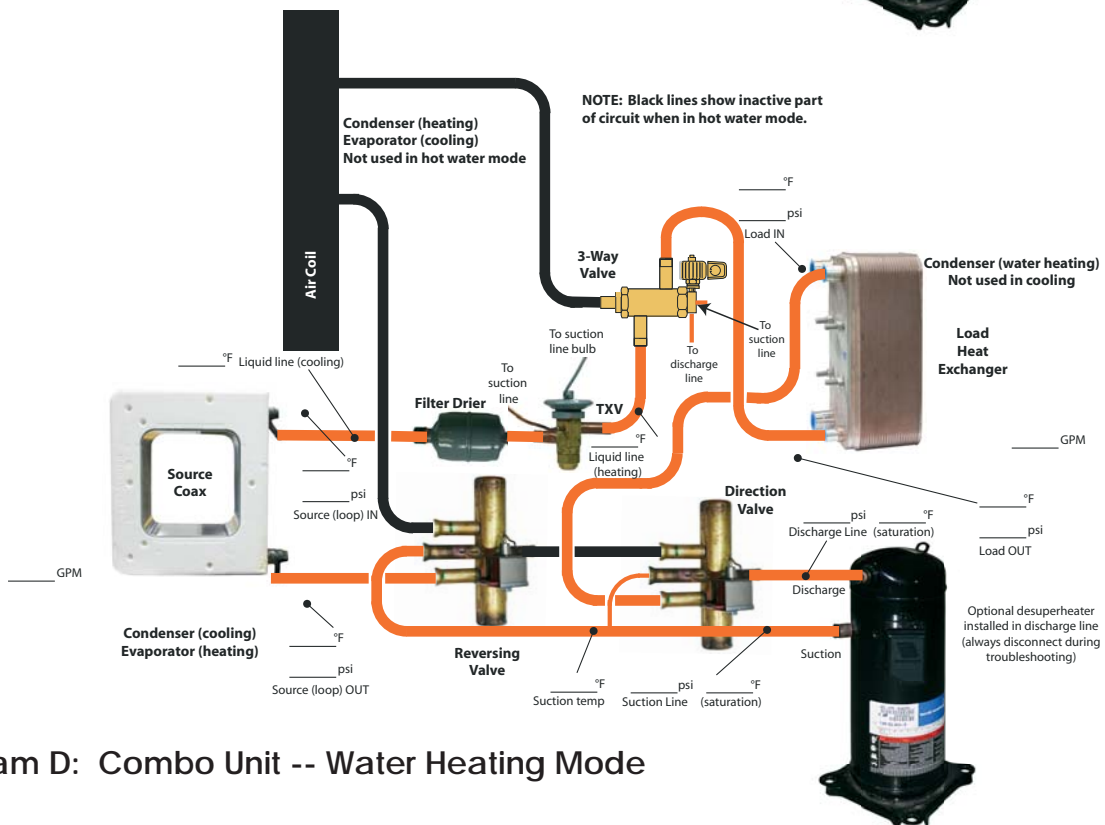

Diagram D: Combo Unit -- Water Heating Mode

EQUIPMENT START-UP FORM

Customer/Job Name: _____ Date: _____

Model #: _____ Serial #: _____

Dealer Name: _____

Check the following before power is applied to the equipment

Note: Start-Up should not occur until the structure is ready to be occupied

ELECTRICAL:

- High voltage wiring is installed correctly
- High voltage wiring & breaker are the correct size
- Auxiliary electric heaters are wired and installed correctly
- Circulating pumps are wired and fused (if necessary) correctly
- Desuperheater pump (if applicable) is NOT wired, unless piping is complete and all air is purged
- Low voltage wiring is correct and completely installed

PLUMBING:

- Pipe and pump sizes are correct
- Air is purged from all lines
- Antifreeze is installed
- All valves are open, including those on the pump kit
- Condensate is trapped and piped to the drain

DUCTWORK:

- Filter is installed and clean
- Bracing is removed from the blower assembly
- Blower turns freely

Equipment Start-Up

Note: Steps should be followed in order

Note: Equipment operation will vary with thermostat brand and model. Refer to thermostat instructions

1. Energize equipment with high voltage.
2. Be sure all pumps and valves are open.
3. Set thermostat settings to correspond with application, and set thermostat to "Heat". Place set point above room temperature. Compressor will start after thermostat time delay expires.
4. Check water flow via one or a combination of these 3 methods:
 - A: ΔT (temp difference):
Source (5°-10° F) _____
 - B: Flowmeter:
3 gpm (gallons per minute) per nominal ton of equipment. (Open Loop 1.5 to 2 GPM).
 - C: Pressure Drop:
Refer to Table 12 & 13.
5. Check ΔT of return and discharge air. (18°-30°F) _____
6. If system is two stage or dual capacity, increase set point and verify that second stage engages (increasing air flow). ΔT will remain the same.
7. If system has auxiliary heat, increase set point and verify that auxiliary heat engages ΔT will increase.
8. Switch thermostat to off, Compressor will shutoff.
9. Place thermostat in "Cooling" and decrease set point below room temperature. Compressor will start after thermostat time delay expires.
10. Check water flow via and one or combination of these 3 methods:
 - A. ΔT (temp difference).
Source (6°-12° F) _____
 - B. Flowmeter.
3 GPM (gallons per minute) per nominal ton of equipment. (Open Loop 1.5 to 2 GPM).
 - C. Pressure Drop.
Refer to Table 12 & 13.
11. Check ΔT of return and discharge air. 16°-25° F _____
12. If system is two stage or dual capacity, increase set point and verify that second stage engages (increasing air flow). ΔT will remain the same.
13. If, at anytime, there is excessive noise or vibration, the problem should be fixed and testing resumed.

Note: If a problem occurs during start-up, please do the following:

1. Refer to the troubleshooting sections contained within the unit Installation, Operation, and Maintenance Manual
2. Contact Technical Support at your distributor.

Installer/Technician: _____ Date: _____

Cut along this line



2506 South Elm Street
Greenville, IL 62246
www.enertechmfg.com
info@enertechmfg.com



Enertech Manufacturing is continually working to improve its products. As a result, the design and specifications of each product may change without notice and may not be as described herein. For the most up-to-date information, please visit our website, or contact our Customer Service department at info@enertechmfg.com. Statements and other information contained herein are not express warranties and do not form the basis of any bargain between the parties, but are merely Enertech Manufacturing's opinion or commendation of its products.